

modena

Fliser – inspirert av naturen

1

bassengprogram

Komplette løsninger for store og små basseng, svømmehaller og badeanlegg til offentlig, næring og privat

innhold numerisk

Modena bassengteam	4
Bassengfliser	6
Rennesystemer	10
Promenadedekke	18
Mosaikk og dekorativt	32
Tilbehørsartikler	42
Dusjo og garderober	44
Hotell og spa	50
Private basseng	58
Naturstein til basseng	60
Teknisk info	62
Kvalitetsmerker	63

**giskehallen,
sandnes**



stavanger
SINDRE IVERSEN
+47 980 12 578



oslo
KNUT-JARLE ROGNMO
+47 928 61 110



kristiansand
LARS KRISTENSEN
+47 990 06 924



stavanger
BJARTE EGELAND
+47 922 07 956



bergen
OVE STAMNESHAGEN
+47 988 99 450



trondheim
STÅLE BRÅTEN
+47 951 48 252

Modena er en av Skandinavias ledende leverandør av keramiske fliser, både til private og offentlige bygg. Helt siden 1986 har vi levert fliser til det norske markedet fra noen av verdens mest renommerte produsenter.

I løpet av denne tiden har vi etablert oss til å bli en av de største leverandørene på bassengløsninger. Vår lange erfaring og dedikerte bassengteam har erfaringen du ønsker som samarbeidspartner til ditt bassengprosjekt.

svømmehaller

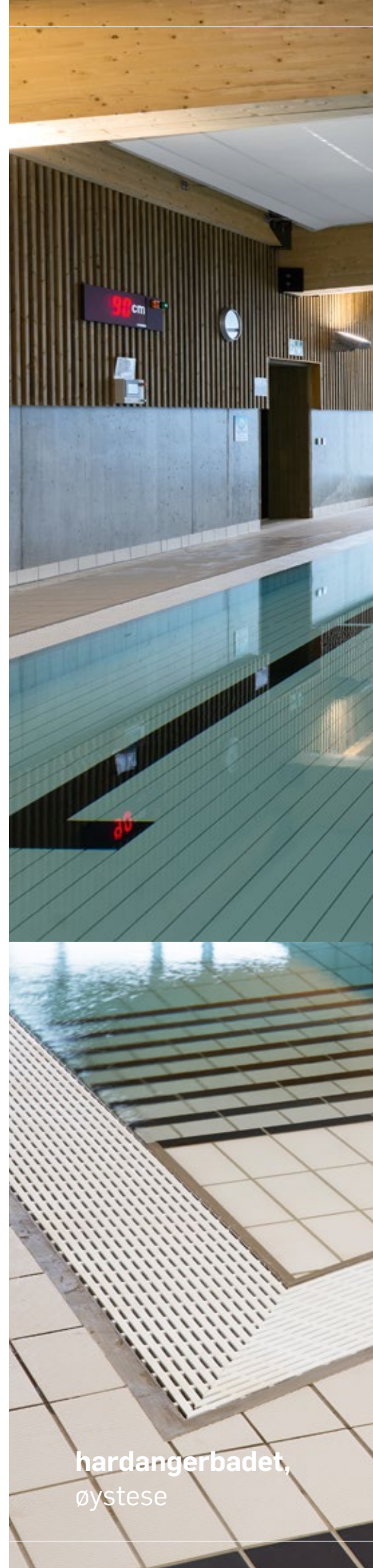

hardangerbadet,
øystese





Fargene på VarioCOLOR-paletten ble designet i henhold til de mest moderne bruksområder. Et balansert fargevalg tilbyr klare og sterke farger fra hele fargespekteret. Satengfinishen til hovedfargene ser elegant ut og kan brukes nesten hvor som helst. Klare uttrykk med 6 intensive og 5 grunnfarger å velge mellom. I kombinasjon med det brede utvalget av støpte deler gir det et nyskapende designkonsept som kan implementeres på en rekke måter.

variocolor

Beskrivelse Glaserte fliser
Overflate Satin
Formater 12,5 x 12,5 cm, 6,25 x 25cm, 12,5 x 25 cm og 25 x 25 cm



Yellow



211 Melonengelb 251 Maisgelb 281 Zinkgelb

Orange



411 Gelbbraun 451 Sandbraun 481 Dunkelorange

Green



611 Hellgrün 641 Seegrün 681 Maigrün

Turquoise



621 Aquamarin 661 Türkis 671 Minttürkis

Blue

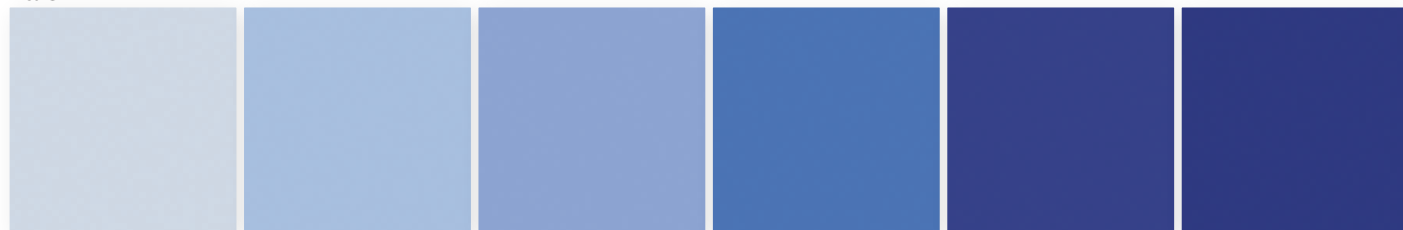

511 Eisblau 521 Pastellblau 531 Kornblomenblau 541 Royalblau 561 Dunkelblau 581 Ultramarinblau

Azure



721 Hellblau 741 Himmelblau 761 Stahlblau 781 Azurblau

Beige

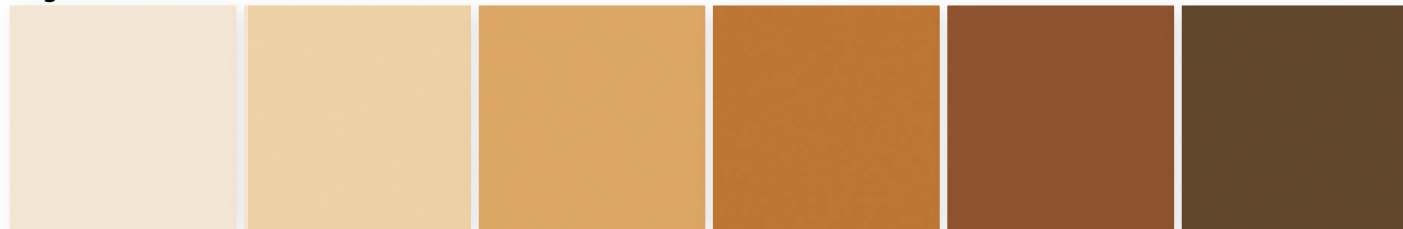

111 Hellelfenbein 121 Beige 141 Braunbeige 151 Orangebraun 171 Signalbraun 191 Terrabraun

Brown

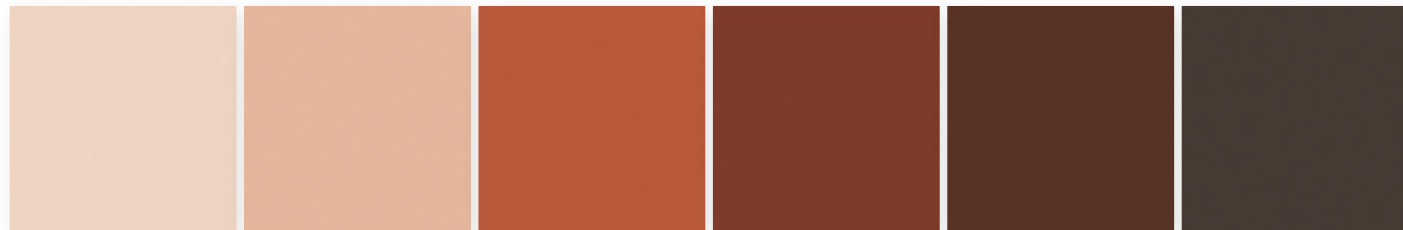

811 Sesam 821 Lachs 841 Sienaerde 861 Sattelbraun 871 Nussbraun 881 Schokobraun

Beskrivelse Glaserte fliser
Overflate Glossy
Formater 12,5 x 12,5 cm, 6,25 x 25cm, 12,5 x 25 cm og 25 x 25 cm



Intensivfarben



270 Schwefelgelb

470 Dahliengelb

490 Orange

370 Feuerrot

630 Gelbgrün

650 Limette

Basisfarben



900 Weiss

710 Lichtblau

790 Azur dunkel

590 Kobaltblau

990 Schwarz

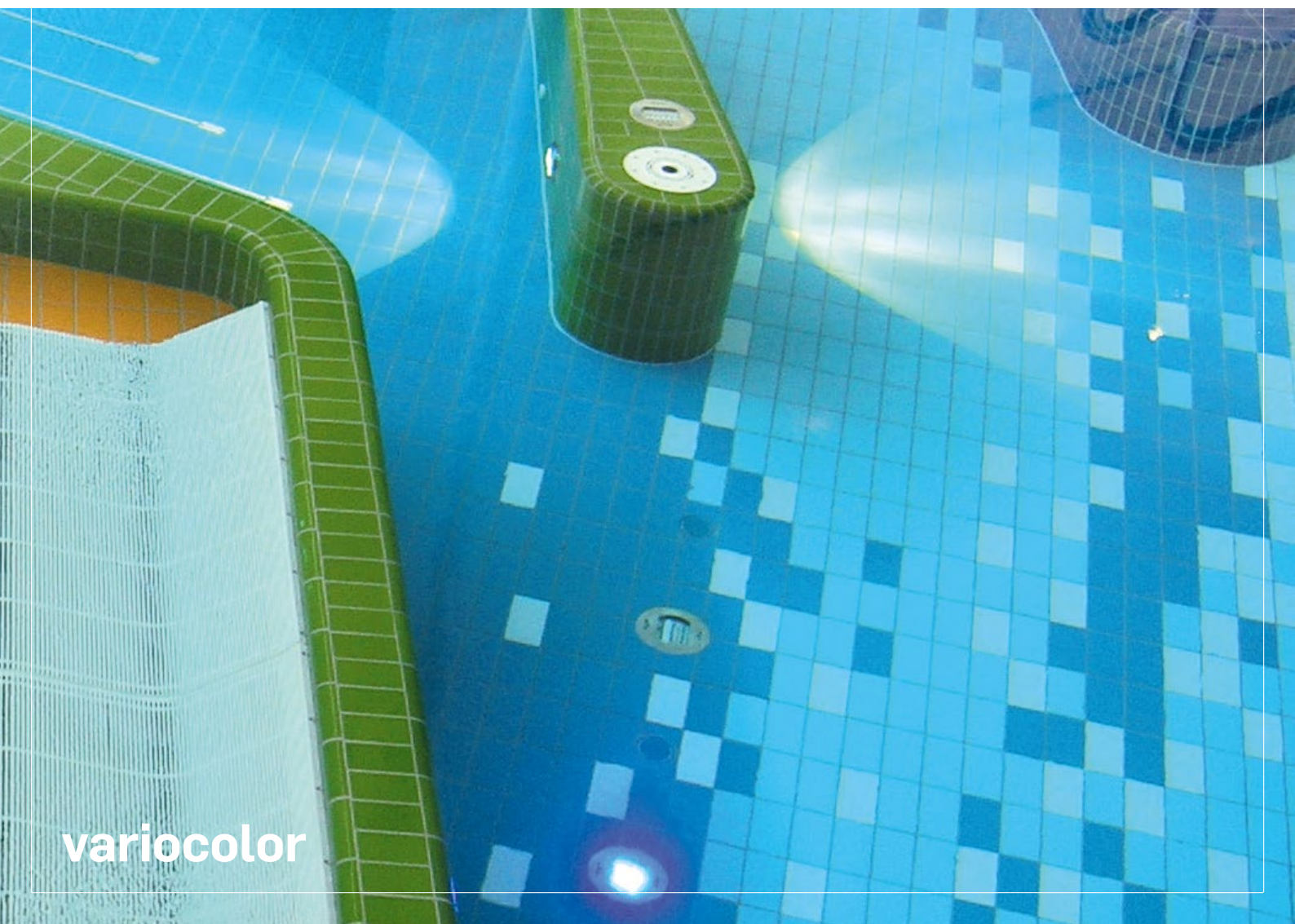

variocolor

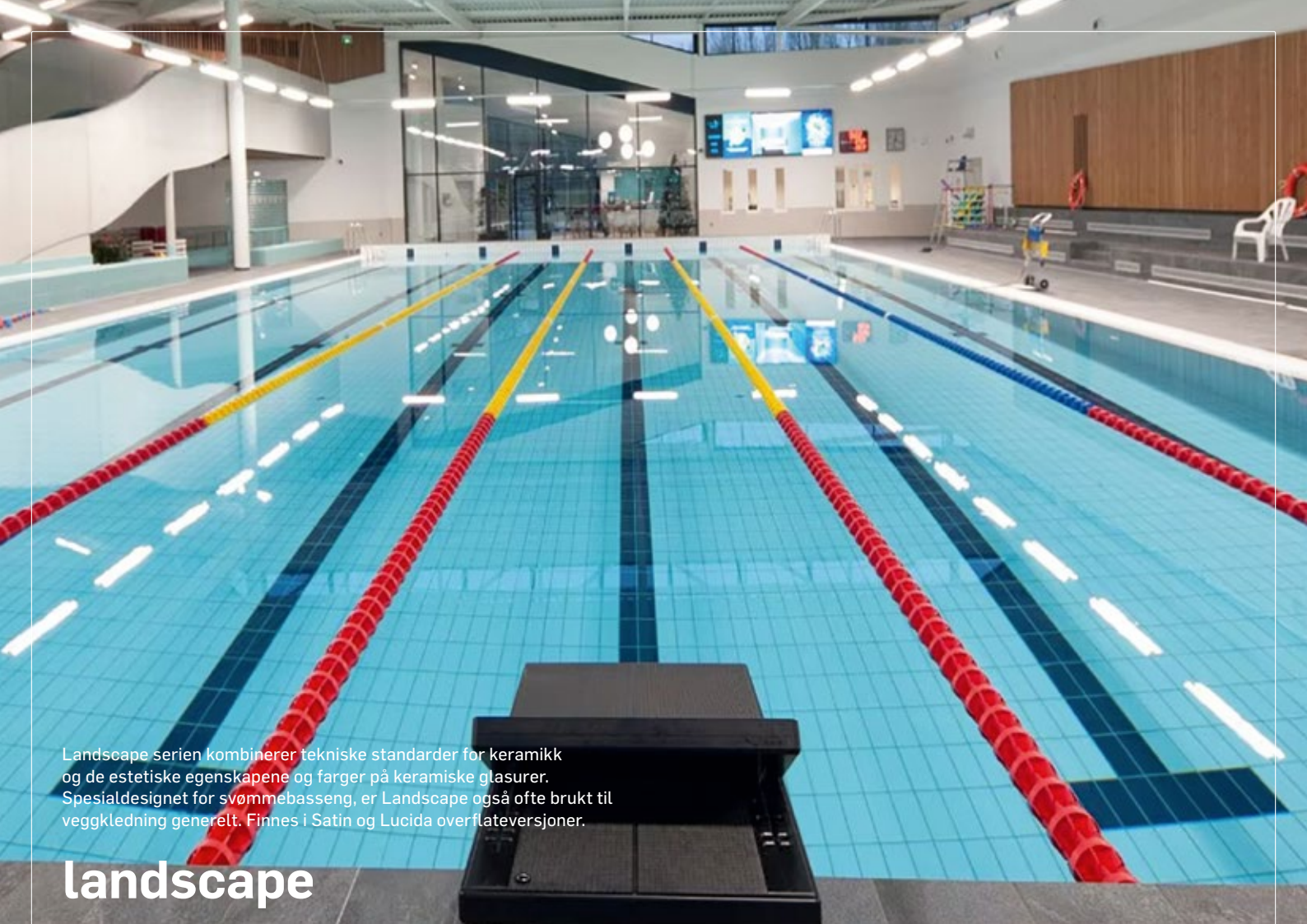

Landscape serien kombinerer tekniske standarder for keramikk og de estetiske egenskapene og farger på keramiske glasurer. Spesialdesignet for svømmebasseng, er Landscape også ofte brukt til veggkledning generelt. Finnes i Satin og Lucida overflateversjoner.

landscape

Beskrivelse Glaserte fliser
Overflate Satin (A), Grip (C)
Formater 12,5 x 12,5 cm, 12,5 x 25 cm og 25 x 25 cm. Tykkelse 8 mm.



Bahama

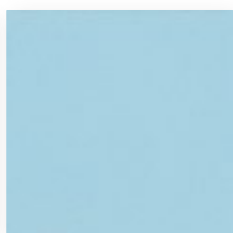

Bay



Lava



Ocean

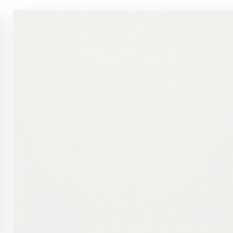

Tundra

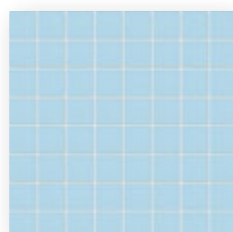

Dec Uni Bay

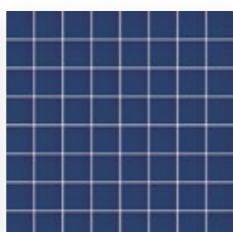

Dec Uni Ocean

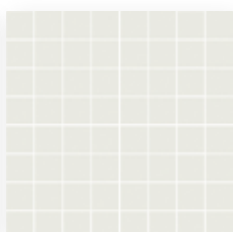

Dec Uni Tundra

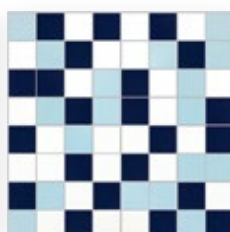

Dec Mix 840

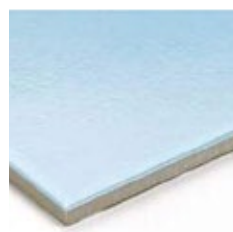

Satin

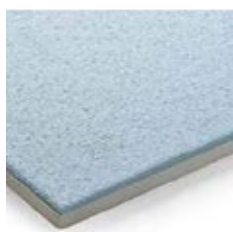

Grip

Rennesystemer til svømmebassenger er en viktig del av bassengens konstruksjon og drift. Disse systemene bidrar til å holde vannet rent, klart og i bevegelse.

rennesystemer



giskehallen,
sandnes



dysjalandshallen,
sola



Fotograf: Hugo Lütcherath





- A Basic tile standard / glazed
- B Basic tile standard / antiskid / glazed
- C Overflow channel, small
- D Overflow channel with drainage
- E Grating, rigid
- F Drain valve, silent, 2 ½"

- 1 Expansion joint
- 2 Joint band
- 3 Expansion joint with polyethylen foam round lace
- 4 Slide bearing
- 5 Capillary break joint filling
- 6 Water resistant concrete

Monteringen av Wiesbaden-systemet med en høy vannstand har ulike funksjoner. Den gir et trygt grep for svømmerne og er samtidig en renne med riststøtte. Vannstanden er ca. 3 cm over bassengkanten, noe som gir mange fordeler:

- Enkel overvåking av svømmere
- God sikt utover
- Eliminering av klorklokken

wiesbaden høy vannstand



Bred kanal

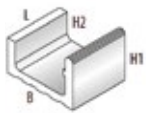

5300 Overflow channel
Large
244x300x200 | 140 mm

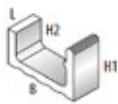

5305 Overflow channel
Large 1/2
119x300x200 | 140 mm

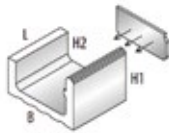

5304/5306 Stopp ende.
Sett med to stk.
244x300x200 | 140 mm

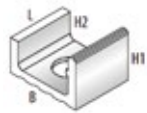

5301 Overflow channel
med drenering.
244x300x200 | 140 mm



5302 Indre hjørne
Sett med to stk.
(2 x) 293x300x140 mm



5307 Ytre hjørne
Sett med fire stk.
(two times each)
238x244x300x200 mm

Smal kanal

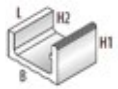

5300 Overflow channel
Small
244x225x160 | 115 mm



5175 Overflow channel
Small 1/2
119x225x160 | 115 mm

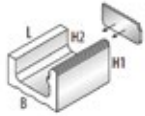

5174/5176 Stopp ende.
Sett med to stk.
244x225x160 | 115

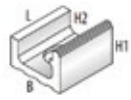

5171 Overflow channel med
drenering.
244x225x160 | 115 mm



5172 Indre hjørne
Sett med to stk.
(2 x) 215x225x115 mm

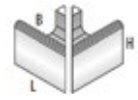

5177 Ytre hjørne
Sett med fire stk.
(two times each)
(2 x) 238x225x160 mm

Bred kanal (for mosaikk i front)

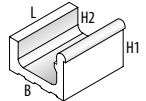

5500 Overflow channel
Large
244x300x200 | 140 mm

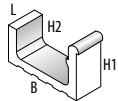

5505 Overflow channel
Large 1/2
119x300x200 | 140 mm

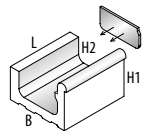

5504/5506 Stopp ende.
Sett med to stk.
244x300x200 | 140

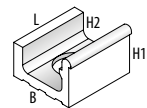

5501 Overflow channel
med drenering.
244x300x200 | 140 mm

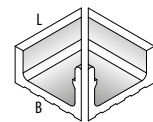

5502 Indre hjørne
Sett med to stk.
(2 x) 293x300x140 mm

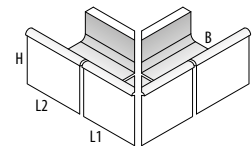

5507 Ytre hjørne
Sett med fire stk.
(two times each)
238x244x200 mm

Smal kanal (for mosaikk i front)

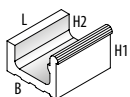

5300 Overflow channel
Small
244x225x160 | 115 mm

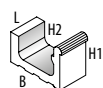

5175 Overflow channel
Small 1/2
119x225x160 | 115 mm

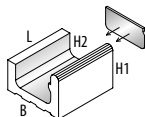

5174/5176 Stopp ende.
Sett med to stk.
244x225x160 | 115 mm

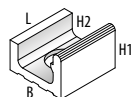

5171 Overflow channel med
drenering.
244x225x160 | 115 mm

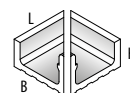

5172 Indre hjørne
Sett med to stk.
(2 x) 218x225x115 mm

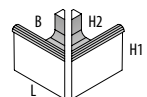

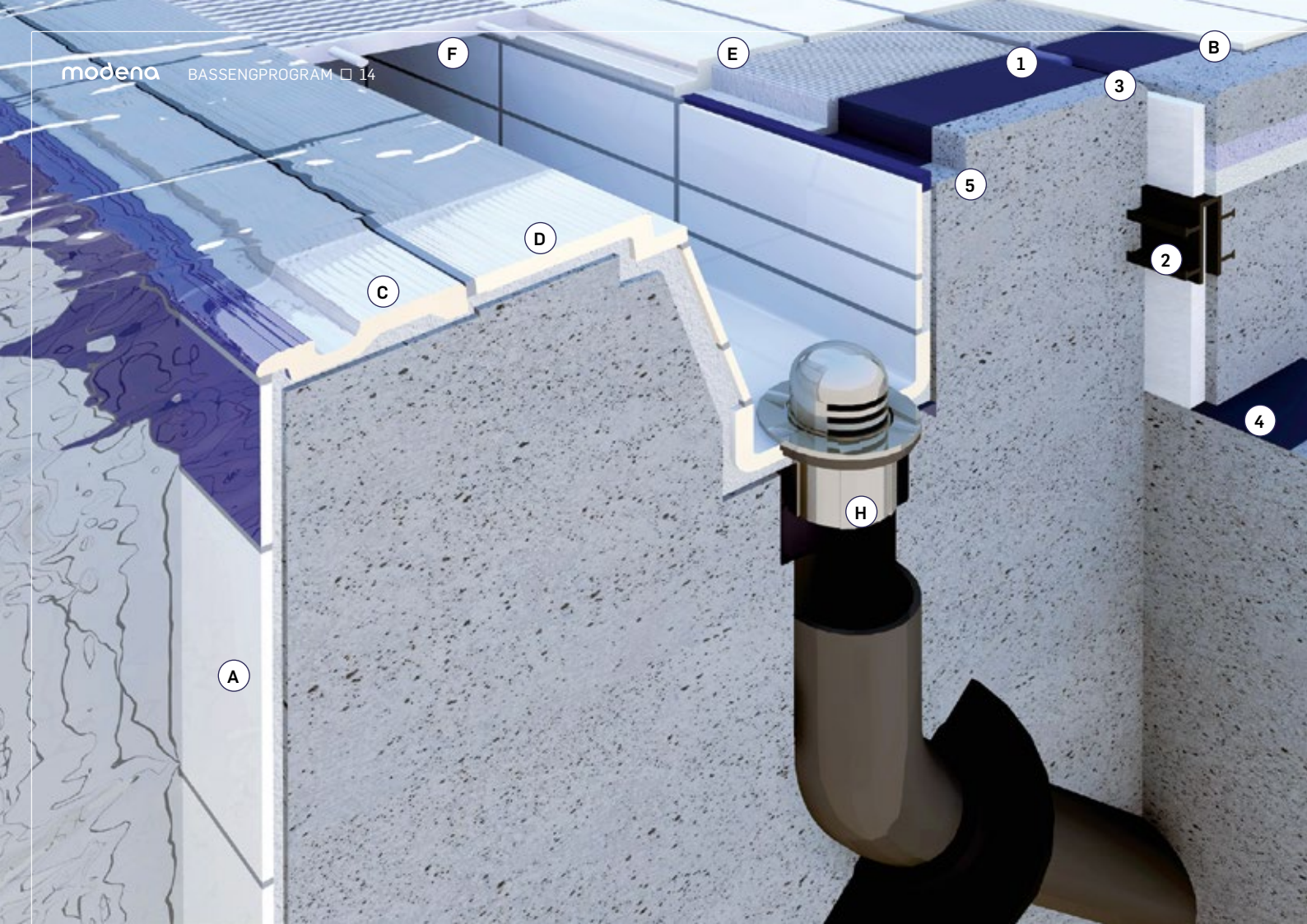

5177 Ytre hjørne
Sett med fire stk.
(two times each)
(2 x) 238x225x160 | 115 mm



- A Basic tile standard / glazed
 - B Basic tile standard / antiskid / glazed
 - C Hand grip tile
 - D Grooved tile with grating support / 107°
 - E Edging tile with grating support
 - F Grating, rigid
 - G Channel with drainage
 - H Drain valve, silent, 2 ½"
-
- 1 Expansion joint
 - 2 Joint band
 - 3 Expansion joint with polyethylen foam round lace
 - 4 Slide bearing
 - 5 Capillary break joint filling
 - 6 Water resistant concrete

Støtteprofiler for overvannsrenner

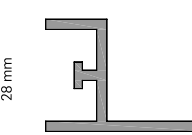
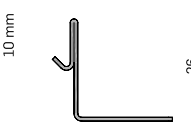
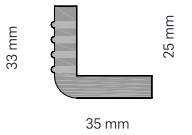
		
15 mm 25 mm	5 mm 25 mm	8 mm
		
28 mm	10 mm	33 mm
40 mm	26	25 mm
35 mm		
SL25 PVCB* Padana-Grid PVC Hvit	SL25 IR16 Padana-Grid Rustfritt stål* Polert	0500 100S Padana-Grid Keramikk Hvit 100 Tu glassert

*Lagres utenfor sollys og under temperatur 40°C

*AISI 316L – BA EN 1.4404 Korrosjonsklasse C4

Finland løsningen øker strandeffekten og hever vannstanden. Bølgerrefleksjon reduseres i bassenget. Vannoverflaten er fullt syntlig og derfor forbedres den passive sikkerheten til badende. Vannet kan renne fritt rundt bassengoverflaten og det trengs ingen klorklokke, fritt for irriterende lukter.

finland 3 høy vannstand



Fliser med sikkerhetsmarkering

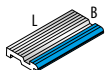

5730 Bassengkantflis
m/vertikal front
240 x 115 mm



5732 Indre hjørne
Sett med to stk.
108 x 115 mm (x2)



5737 Ytre hjørne
Sett med to stk.
238 x 115 mm (x2)

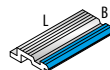

5810 Bassengkantflis
m/håndgrep
240 x 140 mm



5812 Indre hjørne
m/håndgrep.
Sett med to stk.
133 x 140 mm (x2)

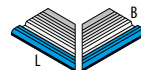

5817 Ytre hjørne m/front
m/håndgrep.
Sett med to stk.
238 x 140 mm (x2)

Fliser med sikkerhetsmarkering

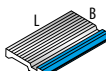

5740 Flis med håndgrep
244 x 150 mm



5742 Indre hjørne
Sett med to stk.
(2 x) 108 x 150 mm

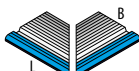

5747 Ytre hjørne
Sett med to stk.
(2 x) 238 x 150 mm

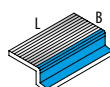

Med kant

5820 Grooved tile
med støtte for rist
244 x 140 mm

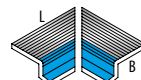

5822 Indre hjørne
Sett med to stk.
(2 x) 238 x 140 mm



5827 Ytre hjørne
Sett med to stk.
(2 x) 133 x 140 mm

Fliser uten sikkerhetsmarkering

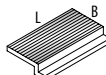

5830 Kantflis
med støtte for rist
244 x 140 mm

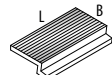

5930 Kantflis 83°
med støtte for rist
244 x 140 mm

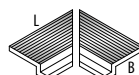

5832 Indre hjørne
Sett med to stk.
(2 x) 238 x 140 mm



5837 Ytre hjørne
Sett med to stk.
(2 x) 133 x 140 mm

Rennekanaler

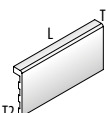

9039 Vinklet flis
med støtte for rist
244x115x25x10 mm

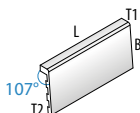

9050 Kantflis 107°
med støtte for rist
244x115x25x10 mm

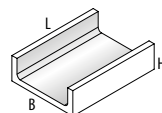

4900 Kanal
for rennekledning
244x180x65 mm

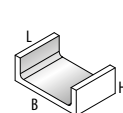

4905 1/2 Kanal
for rennekledning
119x180x65 mm

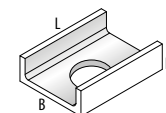

4901 Kanal m/drenering
for rennekledning
244x180x65 mm

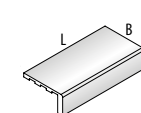

4822 Utvendig
vinklet flis
244x115x52x10 mm

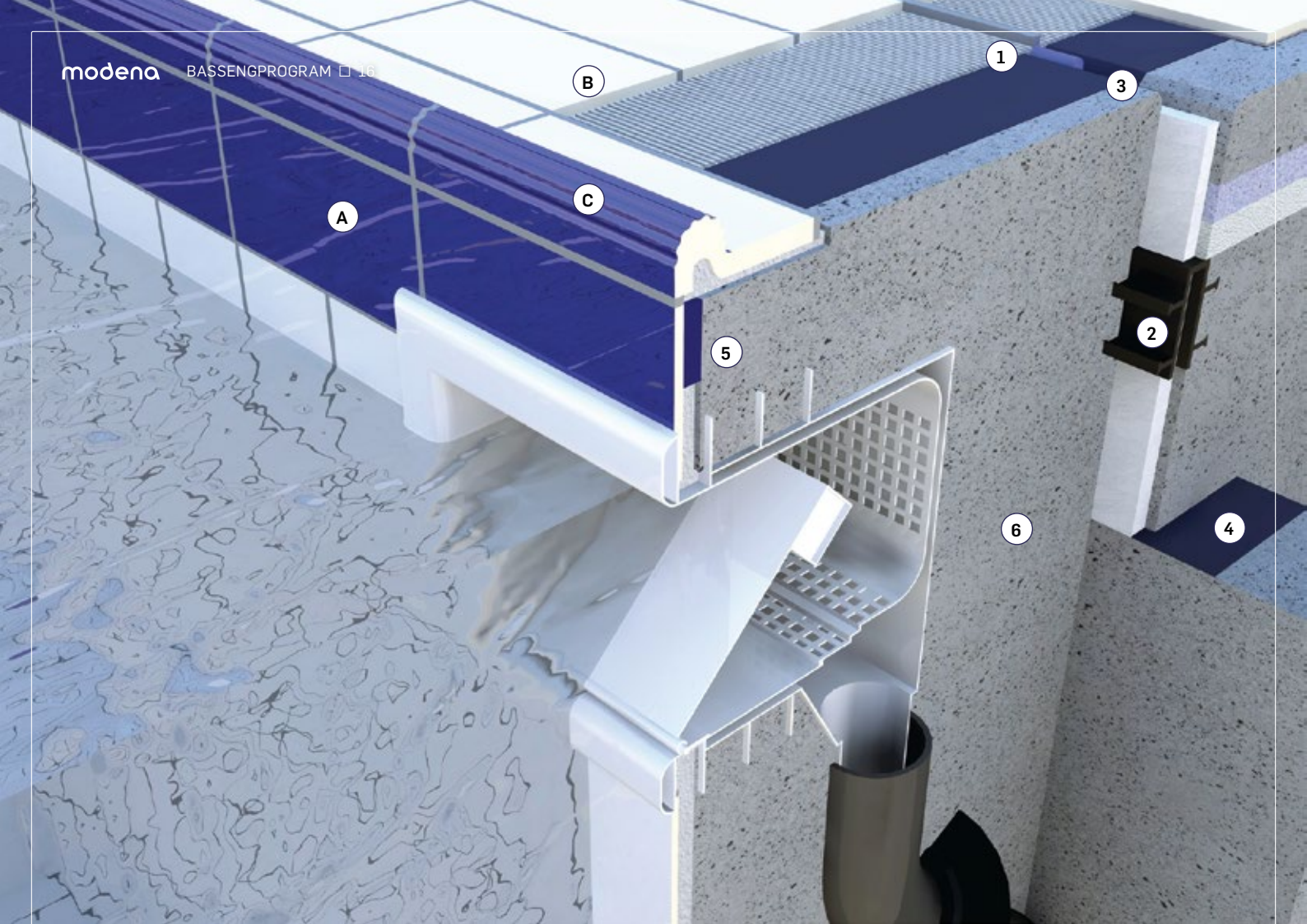

- A Basic tile standard / glazed
- B Basic tile standard / antiskid / glazed
- C Pool edging tile

- 1 Expansion joint
- 2 Joint band
- 3 Expansion joint with polyethylen foam round lace
- 4 Slide bearing
- 5 Capillary break joint filling
- 6 Water resistant concrete

formede fliser med sikkerhetsmarkering

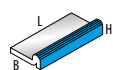

5750 Bassengkantflis
m/vertikal front
244 x 115 x 45 mm



5752 Indre hjørne
Sett med to stk.
115 mm (x2)



5757 Ytre hjørne m/front
Sett med to stk.
238 x 115 x 45 mm (x2)

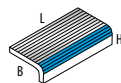

5480 Bassengkantflis
244 x 180 x 50 mm



5482 Indre hjørne
Sett med to stk.
115 mm (x2)

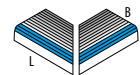

5487 Ytre hjørne
Sett med to stk.
238 x 180 x 50 mm (x2)

kantfliser med striper

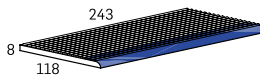

3346 Banda Blu striper
243x118x8 mm

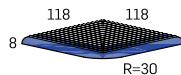

3346 Banda Blu stiper
118x118x8 mm R=30



3346 Banda Nera striper
243x118x8 mm



3346 Banda Nera stiper
118x118x8 mm R=30

kantfliser med knotter

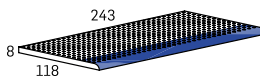

3356 Banda Blu knotter
243x118x8 mm

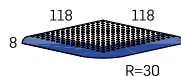

3359 Banda Blu knotter
118x118x8 mm R=30



3356 Banda Nera knotter
243x118x8 mm

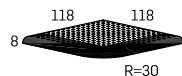

3359 Banda Nera knotter
118x118x8 mm R=30

Vi tilbyr et stort utvalg kantløsninger som kan benyttes sammen med skimmerløsninger. Brukes primært i private basseng. Ta kontakt for mer informasjon og løsninger.

skimmer lav vannstand

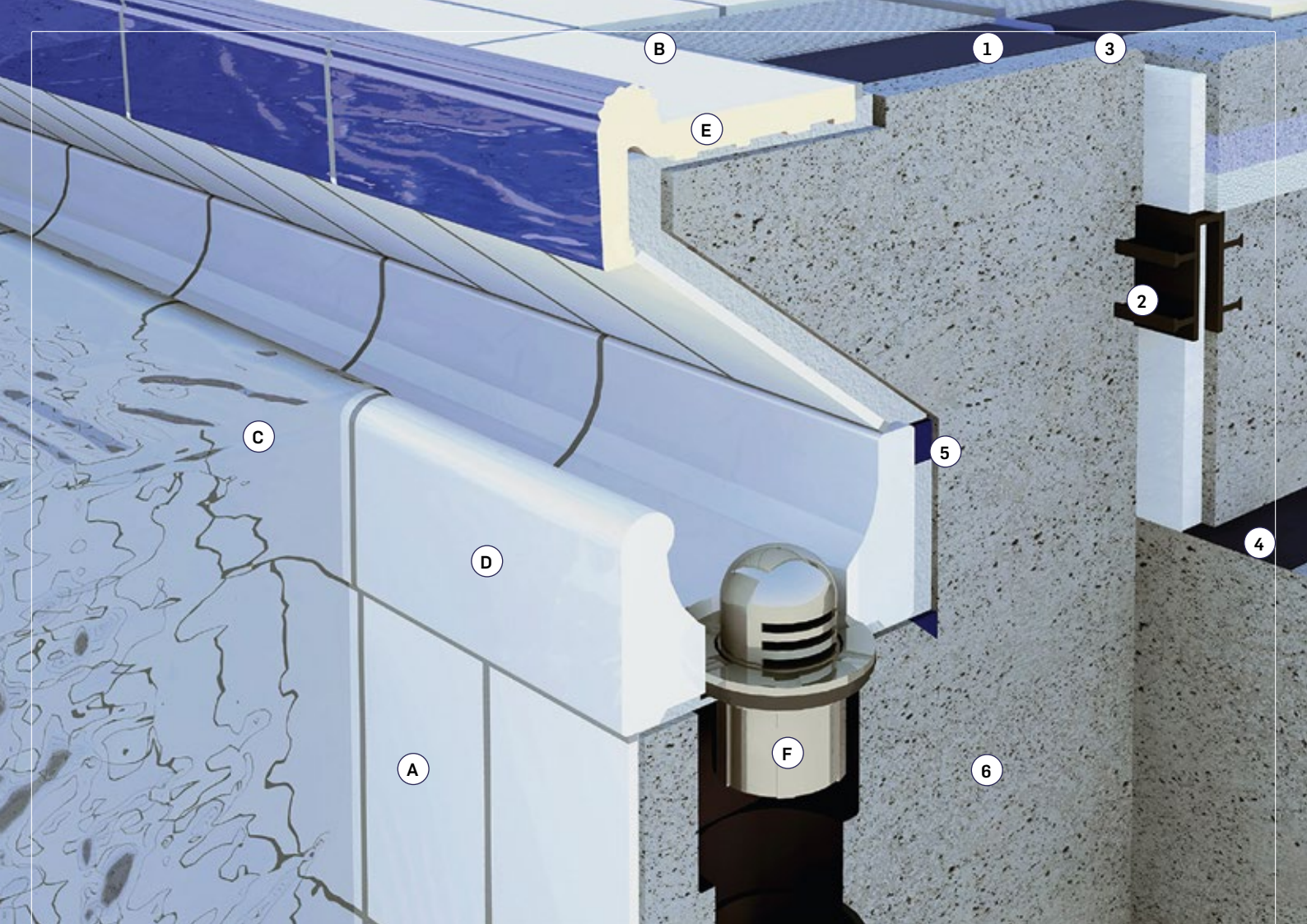

- A Basic tile standard / glazed
- B Basic til standard / antiskid / glazed
- C Overflow channel
- D Overflow channel with drainage
- E Pool edging tile
- F Drain valve, silent, 2 ½"

- 1 Expansion joint
- 2 Joint band
- 3 Expansion joint with polyethylen foam round lace
- 4 Slide bearing
- 5 Capillary break joint filling
- 6 Water resistant concrete

wiesbaden kanalløsninger



5100 Overflomkanal
Stor
244 x 215 x 140 mm



5105 Overflomkanal 1/2
Stor
244 x 215 x 140 mm

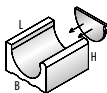

5104 + 5106 Stoppende
Sett med to stk.
244 x 215 x 140 mm (x2)



5101 Overflomkanal
Stor m/drenering
244 x 215 x 140 mm



5402 Indre hjørne
Sett med to stk.
208 x 215 x 140 mm (x2)

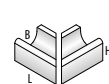

5457 Ytre hjørne m/front
Sett med to stk.
238 x 215 x 140 mm (x2)

formede fliser med vertikalt håndgrep



5400 Bassengkantflis
m/vertikal front
244 x 180 x 100 mm



5402 Indre hjørne
Sett med to stk.
173 x 180 mm (x2)

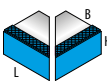

5407 Ytre hjørne m/front
Sett med to stk.
238 x 180 x 100 mm (x2)



5450 Bassengkantflis
m/vertikal front og
håndgrep
244 x 180 x 115 mm



5402 Indre hjørne
m/håndgrep.
Sett med to stk.
173 x 180 mm (x2)

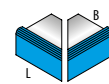

5457 Ytre hjørne m/front
m/håndgrep.
Sett med to stk.
238 x 180 x 115 mm (x2)

Som med oversvømmingsssystem på høyt nivå, brukes et enkelt beslag her som et sikkert grep, som også fungerer som et vannoverløp. En rist er ikke nødvendig. Med dette systemet er vannstanden 20-25 cm under bassengkanten.

wiesbaden lav vannstand



stavanger svømmehall,
stavanger



bjørkebadet
bjørkelangen

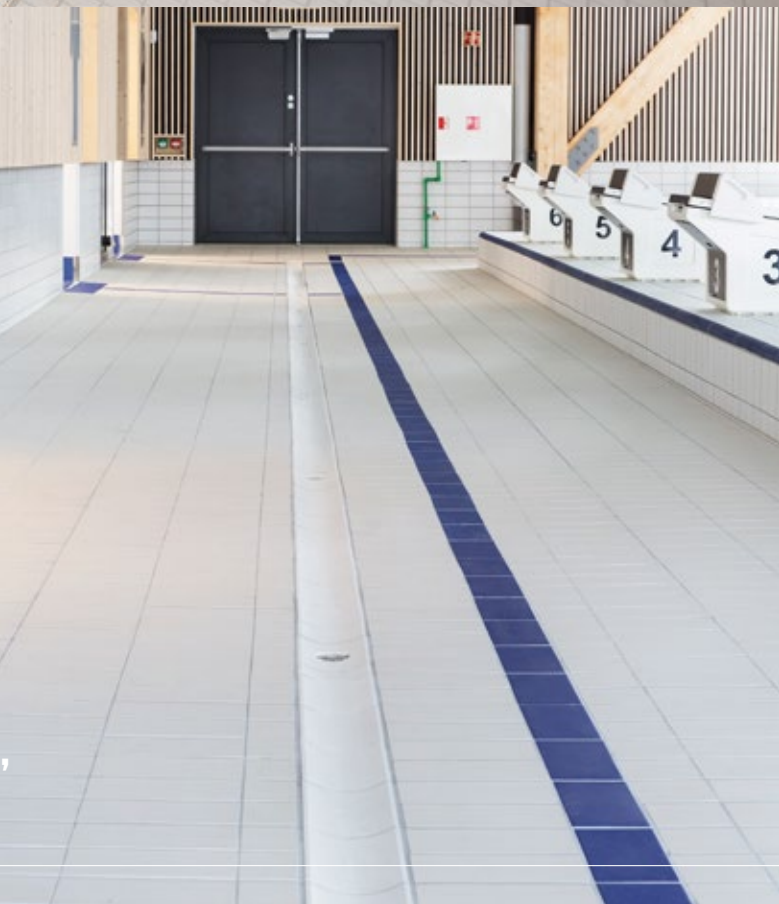

Våre nøye utvalgte kolleksjoner av fliser for promenadedekke kombinerer sikkerhet, funksjonalitet og estetikk på en sømløs måte.

promenadedekke



Beskrivelse Gjennomfarget porcellanato fliser
Overflate Matt R10B, Pinhead R11C og Roccia R12C
Formater 12,5 x 12,5 cm, 12,5 x 25 cm og 25 x 25 cm. Tykkelse 8 mm.

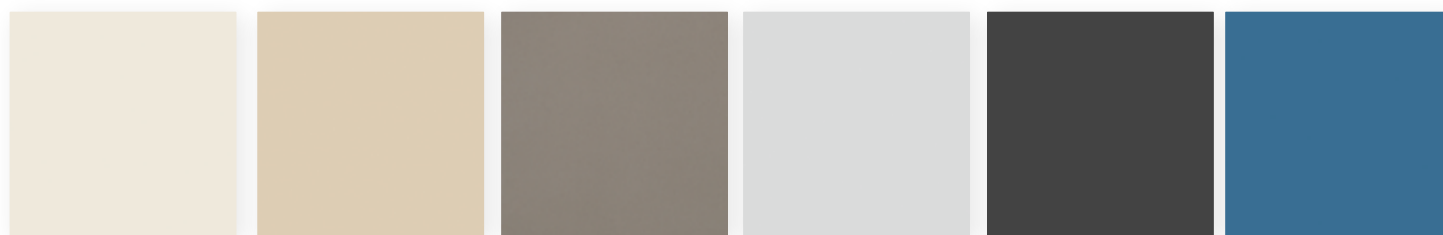

Talco Avorio Basalto Cemento Ebano Mare



Matt Pinhead Roccia
R10 B **R11 C** **R12 C**

Dreneringsvolum V6

formstykker

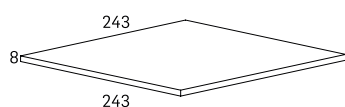

1000 Matt

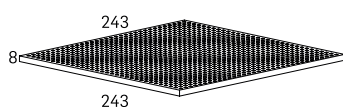

1000 Pinhead

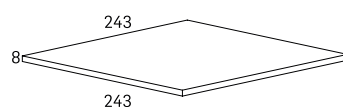

1000 Roccia

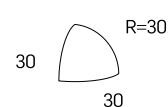

5607

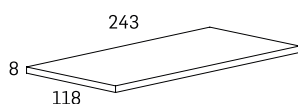

1100 Matt

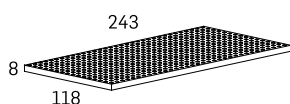

1100 Pinhead

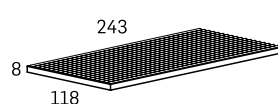

3200 Rigata

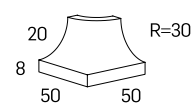

5604

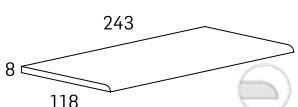

1106 Matt

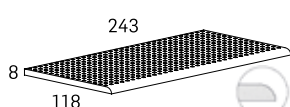

1106 Pinhead

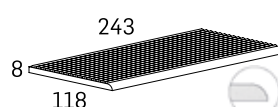

3206 Rigata

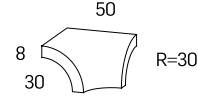

5608

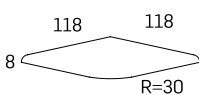

1109 Matt

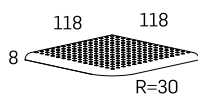

1109 Pinhead

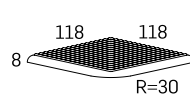

3209 Rigata

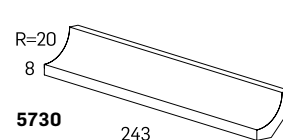

5730

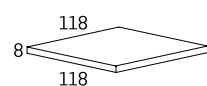

1130 Matt

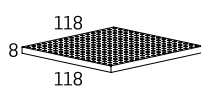

1130 Pinhead

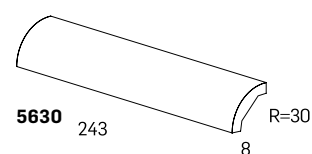

5630

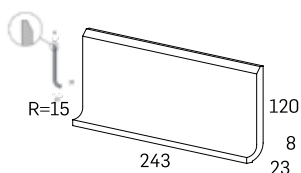

4100 Base

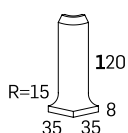

4127 Base

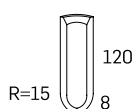

4128 Base



Beskrivelse Porcellanato fliser med et større fargespill og naturtro steinoverflate
Overflate Natural matt R10A og Grip R12C
Formater 30 x 30 cm, 45 x 45 cm, 30 x 60 cm, 60 x 60 cm og 45 x 90 cm.
 Mosaikk 3 x 3 cm, 6 x 6 cm og stavmosaikk. Tykkelse 9 mm.



Dragon White Dragon Beige Eldorado Dragon Brown Dragon Green Dragon Grey



Dragon Black Mosaico Grey 3x3cm Mosaico Grey 6x6cm Composizione A

Sklisikkerhet

Matt



Grip



formstykker

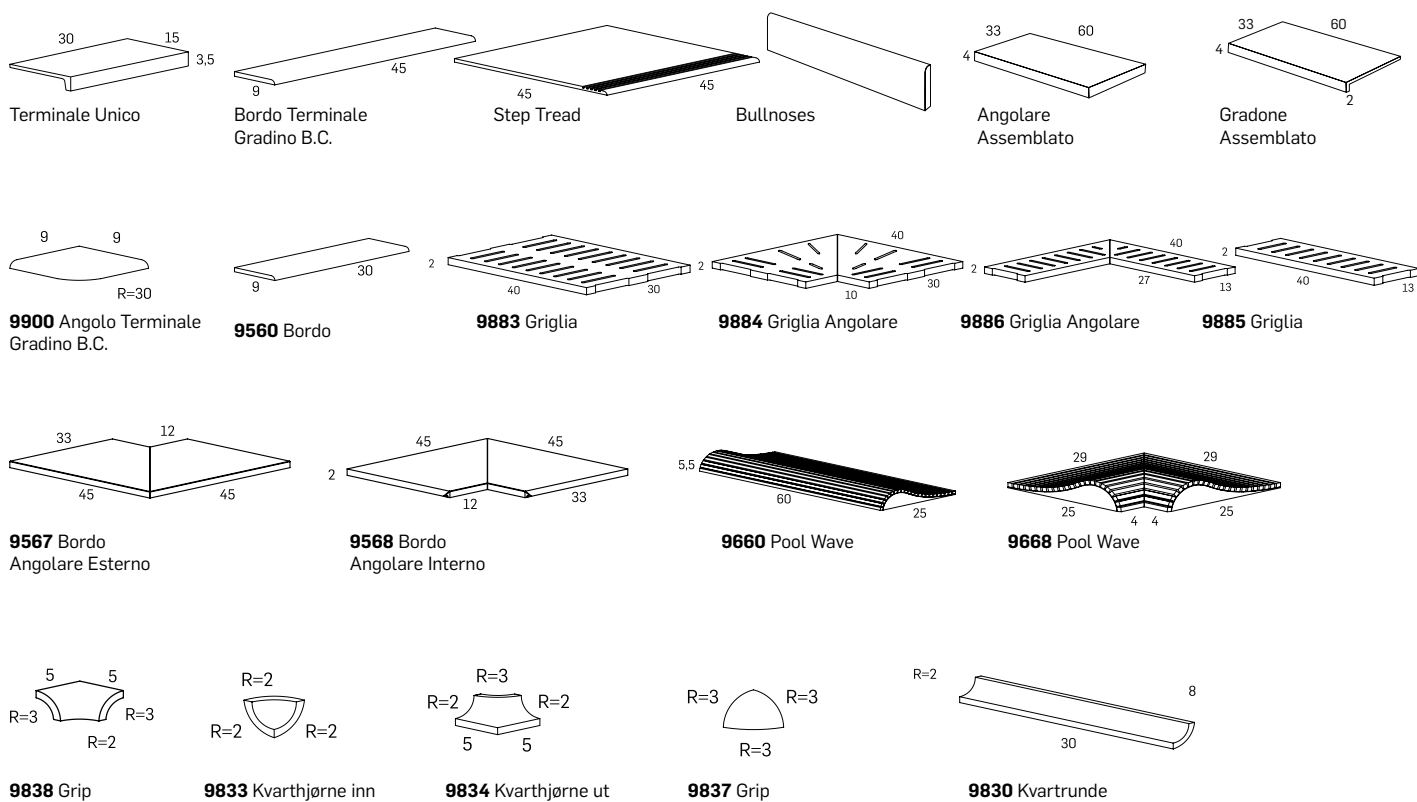



Beskrivelse Porcellanato fliser med et større fargespill og naturtro steinoverflate

Overflate Matt og Bocciardata/struktur

Formater 30 x 30 cm, 30 x 60 cm, 60 x 60 cm



Azul Bahia

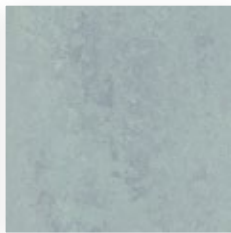

Azul Macauba

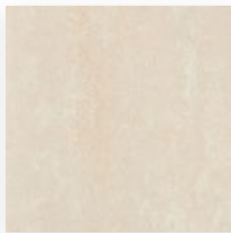

Botticino

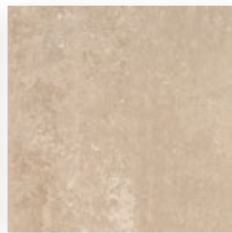

Bronzetto

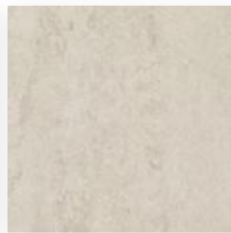

Grigio Egeo



Grigio Maggia



Grigio Marostica

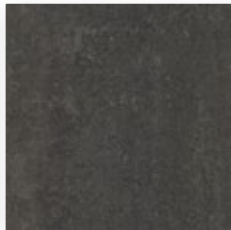

Nero Acapulco

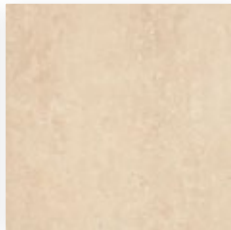

Palissandro



Raggio Di Luna



Ramora Brown



Thassos



Verde Guatamala

Sklisikkerhet

Matt



Bocciardata/struktur



formstykker

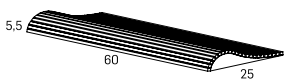

9660 Pool Wave

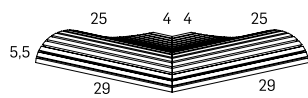

9660 Pool Wave

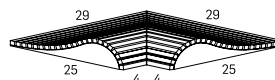

9668 Pool Wave

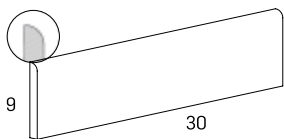

Battiscopa B.C. 9x30

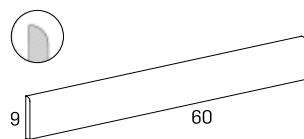

Battiscopa B.C. 9x60

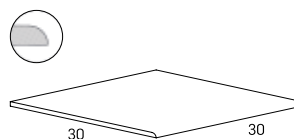

Gradino B.C. 30x30 senza righe

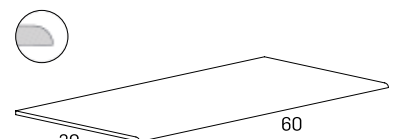

Gradino B.C. 30x60 senza righe

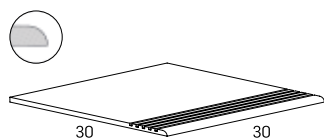

Gradino B.C. 30x30

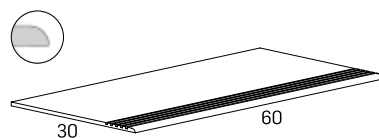

Gradino B.C. 30x60

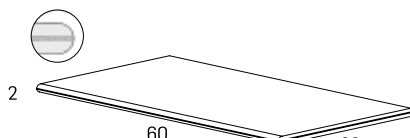

Gradino Toro

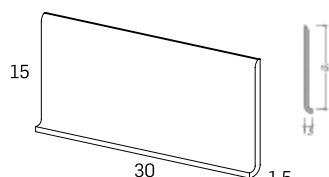

Zoccolo A Raccordo

Beskrivelse Glaserte fliser
Overflate Aticata
Formater 60 x 60 cm, 60 x 120 cm og 90 x 90 cm

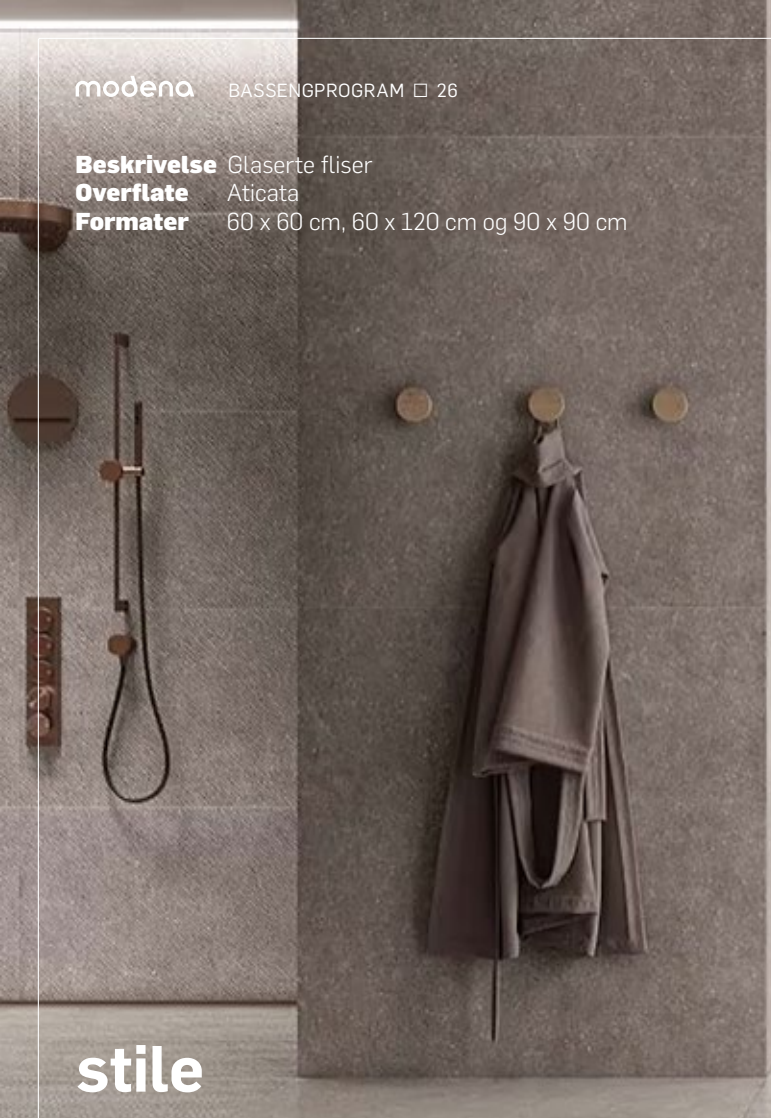

stile

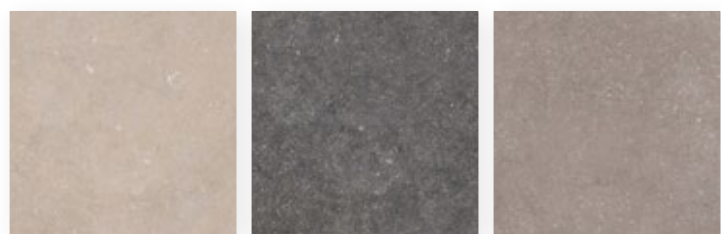

Beige Black French Grey

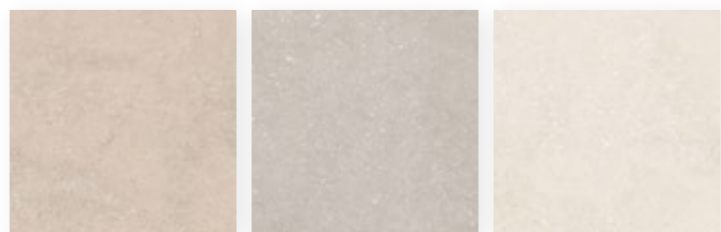

Pale Pearl White Smoke



Mosaico Black 5x15 cm Mosaico Black 5 x5 cm Composizione Black A

formstykker

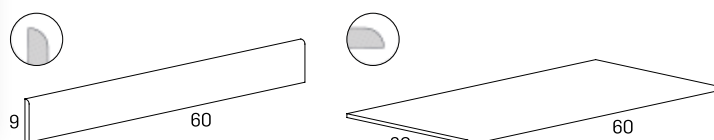

Battiscopa B.C. 9x60

Gradino B.C. 30x60 senza righe

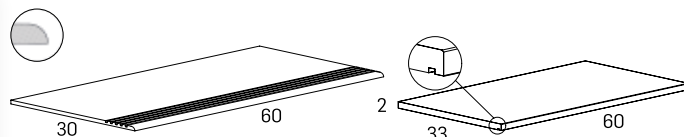

Gradino B.C. 30x60

9550 Bordo

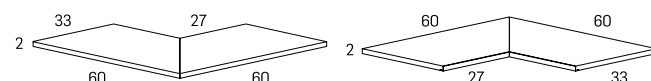

9567 Bordo
Angolare Esterno

9568 Bordo
Angolare Interno

Finnes også i 60 og 90 cm lengde

Beskrivelse Glaserte fliser
Overflate Boccoardato
Formater 12,5 x 12,5 cm, 6,25 x 25cm, 12,5 x 25 cm og 25 x 25 cm



timeless

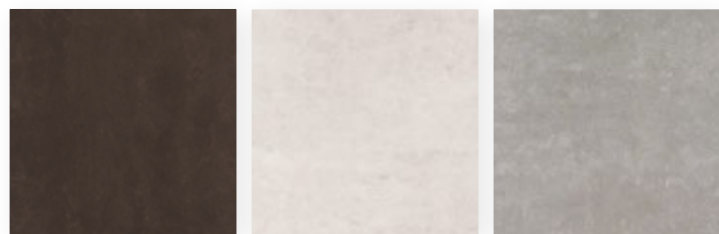

Charcoal

Ice

Seal

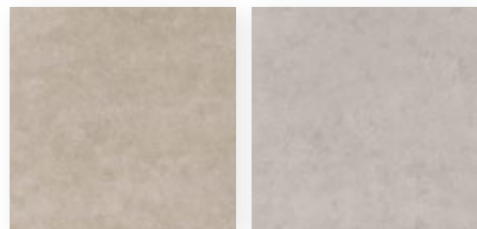

Taupe

Thunder

formstykker

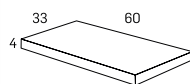

Angolare Assemblato

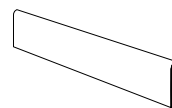

Battiscopa Bullnose

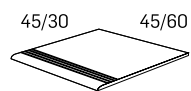

Beton Gradino Righe

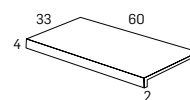

Gradone Assemblato

promenadedekke

Beskrivelse Porcellanato fliser med et større fargespill og naturtro steinoverflate
Overflate Grip
Formater 20 x 20 cm, 20 x 40 cm, 30 x 60 cm, 60 x 60 cm og 60 x 120 cm



petra

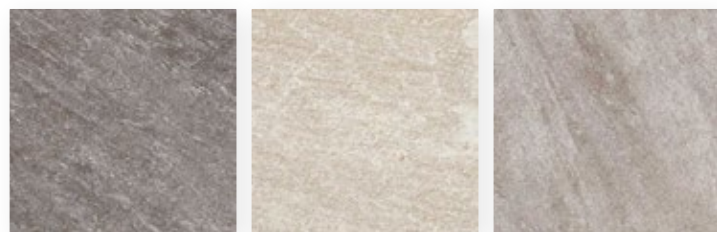

Antracite

Bianco

Grigio

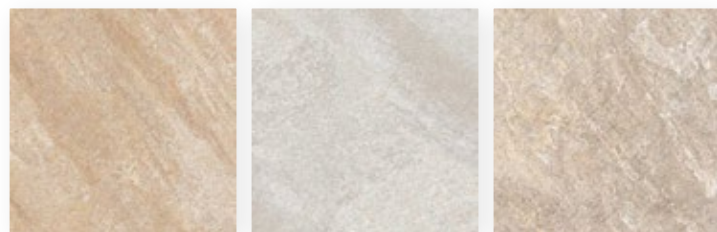

Oro

Perla

Sabbia



Mosaico 5x5 cm

Mosaico 5x15 cm



Composizione A

formstykker

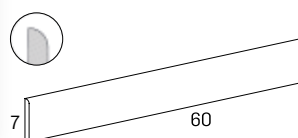

Battiscopa B.C. 9x60



Gradino B.C. 30x60 senza righe

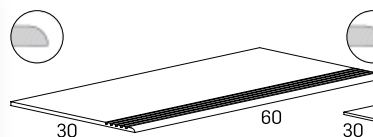

Gradino B.C. 30x60

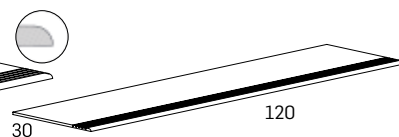

Gradino B.C. 30x120

Beskrivelse Uglaserte fliser
Overflate Matt
Formater 12,5 x 25 cm



variocolor unglaced

R10/B

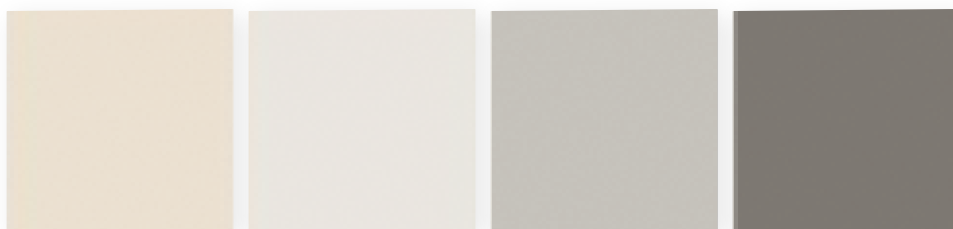

892 Naturbeige R10/B

890 Naturweiss R10/B

894 Neutralgrau R10/B

896 Anthrazit R10/B

Waffelprofil R11/C

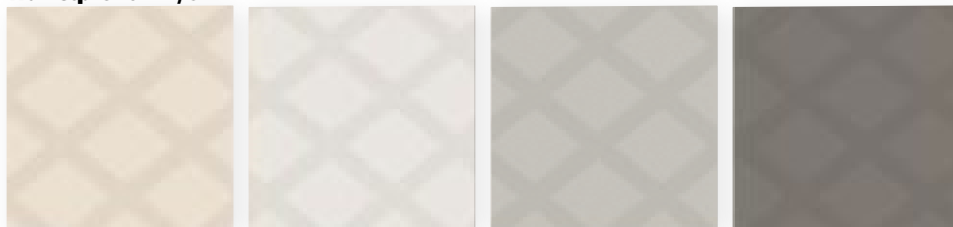

893 Naturbeige

891 Naturweiss

895 Neutralgrau

897 Anthrazit

formstykker

Til variocolor unglaced finnes det et meget stort utvalg formstykker. Ta kontakt med oss for mer informasjon på hele bredden i sortimentet.

Sklisikkerhet

Matt



Vaffelprofil



promenadedekke

spylereenner for promenadedekke

spylerenner for amazzonia, stile, marte, timeless, petra

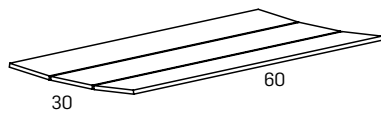

9795

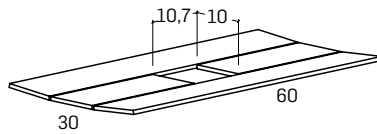

9796

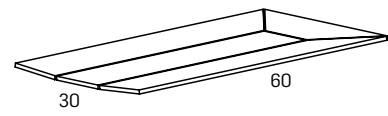

9797

spylerenner for elementi

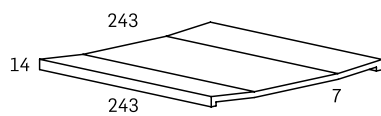

4500

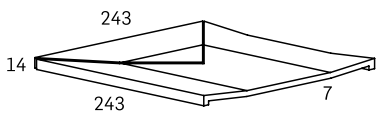

4503 Grip

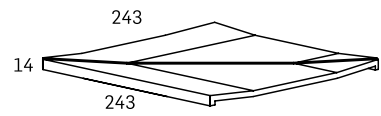

4508 Grip

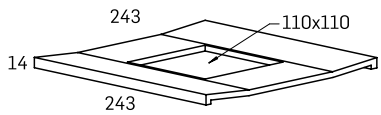

4509 Grip

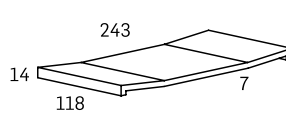

4520 Grip

spylerenner for variocolor

spesialfliser for overskuddsvann

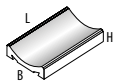

4500 Renne for
åpent kanalsystem
244 x 150 x 35 mm



4505 1/2 Renne for
åpent kanalsystem
244 x 150 x 35 mm

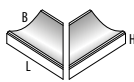

4502 Hjørnerenue
Sett med to stk.
238 x 150 x 35 mm (x2)

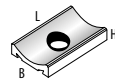

4501 Renne m/drenering
244 x 150 x 35 mm

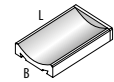

4504 Stop ende renne
244 x 150 x 35 mm

skjulte spylerenner

skjulte renneløsninger er kompatible med alle typer promenadedekke fliser i katalogen

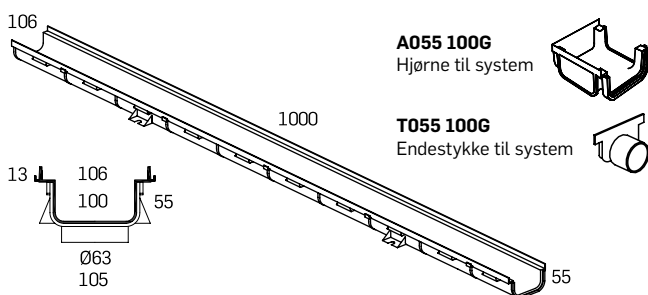

C055 100G Renne for
lukket kanalsystem
1000 x 106 x 55 mm

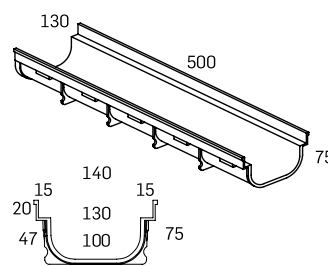

C075 130G Renne for
lukket kanalsystem
500 x 130 x 75 mm

A075 130G
Kryss til system

S075 130G
Innskutt del med avløp

T075 130G
Endestykke til system



hardangerbadet,
øystese

Et svømmebasseng kan inkludere dekorative fliser, og flisene du velger forbedrer bassengets utseende ved å bruke reflekterende lys, intensivere farger og teksturer. Det er også viktig å spesifisere riktig type fliser, for å sikre en høykvalitets finish med høy ytelse. Mosaikkfliser har vært foretrukket siden 3000 f.Kr. Kombinert med dagens materialer og teknikker, gir mosaikkfliser en luksuriøs finish som kan få svømmebassenget ditt til å se enda flottere ut.

mosaikk og dekorativt





Beskrivelse Farget glassmosaikk med moderat fargevariasjon
Overflate Glossy og Antislip R11C
Formater Mosaikk 25 x 25 mm på nett. Tykkelse 4,9 mm.

Onixs Nieve-kolleksjon handler om tilbakeholdenhet og enkelhet. Ved å følge dagens trender, kan denne serien med bassengmosaikk enkelt passe til ethvert nytt basseng eller renovering.

nieve

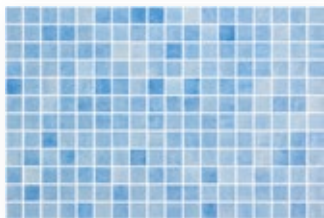

Azul Celeste

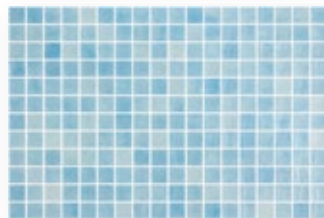

Azul Claro

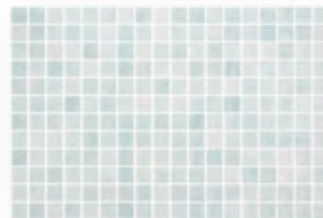

Verde Light

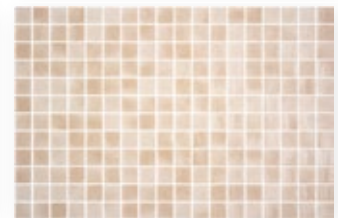

Beige

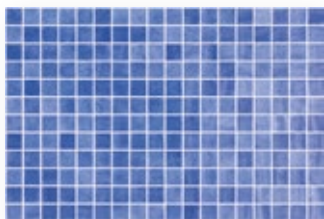

Azul Cielo

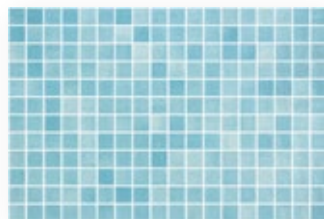

Azul Aguamarina

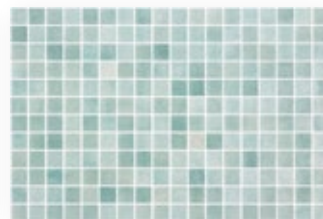

Verde

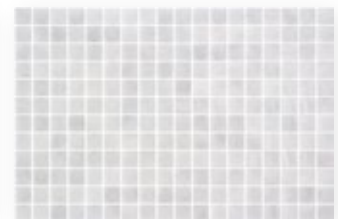

Gris

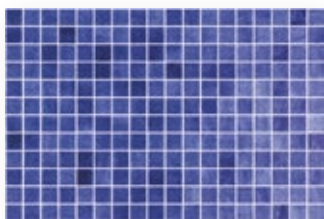

Azul Marino

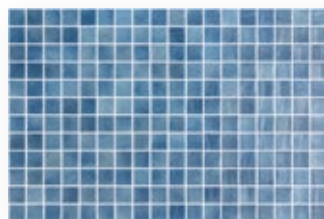

Azul Medio

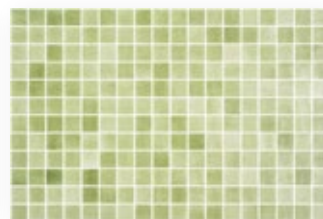

Verde Claro

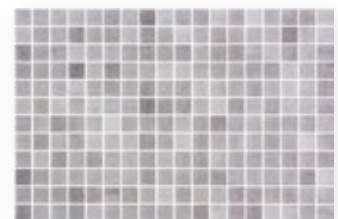

Gris Oscuro

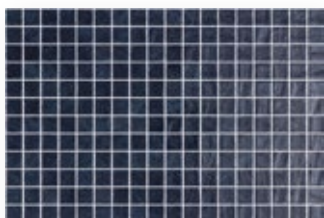

Azul Oscuro

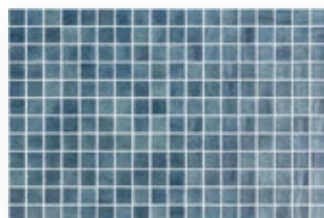

Turquesa



Verde Oscuro

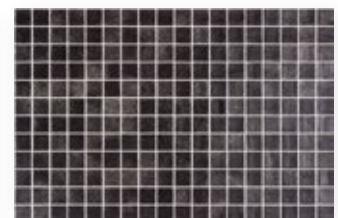

Negro



Azul Aguamarina



Beige



Azul Celeste



Gris



Azul Marino



Verde

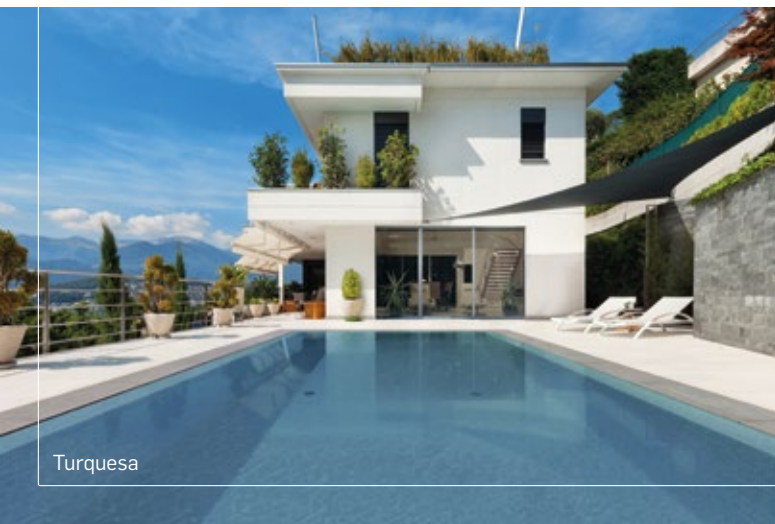

Turquesa

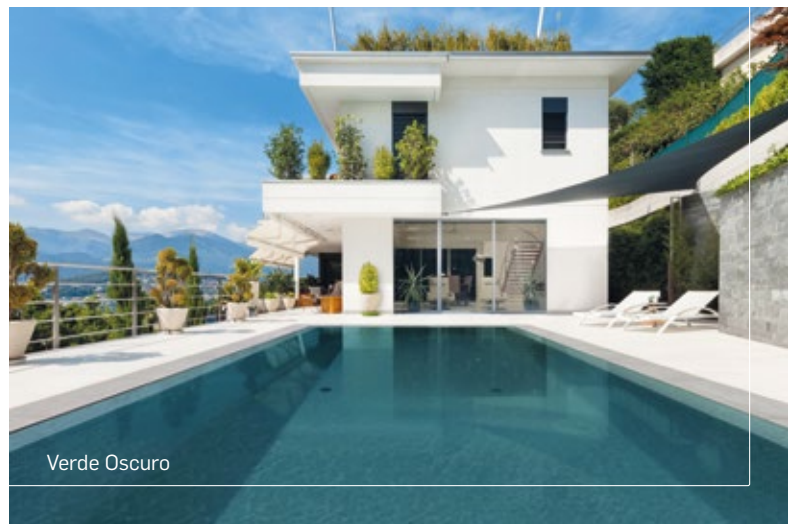

Verde Oscuro

Beskrivelse Glassmosaikk med marmoreringer og et større fargespill
Overflate Glossy og Matt
Formater Mosaikk 25 x 25 mm på nett. Tykkelse 4,9 mm.

Denne serien, inspirert av himmelske strender og linjene i vannbevegelsen under solen, løfter den klassiske paletten av blåtoner til nye høyder. En serie i blank finish med et bredt utvalg av toner og originale teksturer av bølger, koraller, lava og steiner, som kommer sammen for å skape en fargerik komposisjon og fremheve skjønnheten til bassenget og dets omgivelser.

vanguard pool

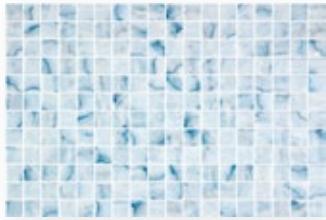

Maureen

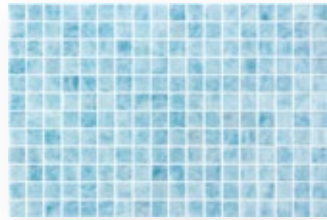

los Blue

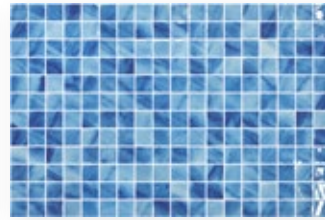

Blue Macauba

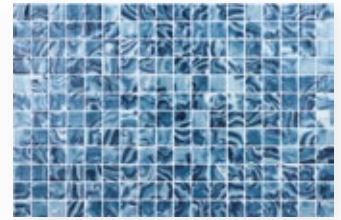

Navagio Luminis

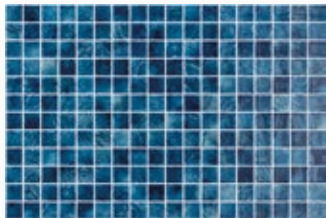

Arrecife Blue



Sena



Saona



Tulum Iridis

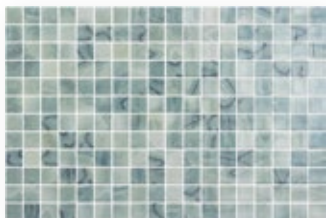

Lungomare



Daria

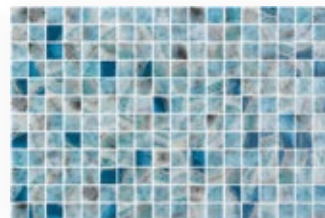

Kara Blue



Tourmaline Blend



Formentor Iridis

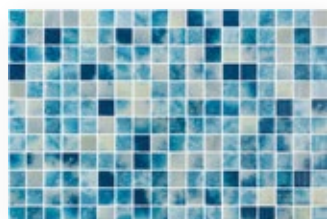

Bluestone Blend



Lake Blend



Kara Beige

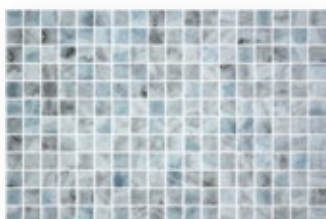

Kara Grey



Rodas

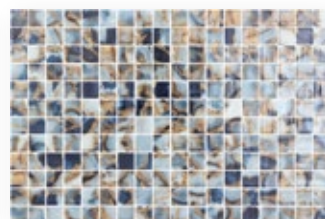

Mauna

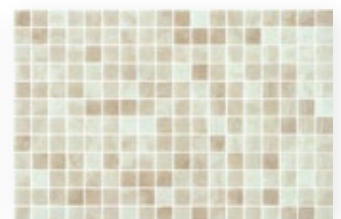

Quartz Beige

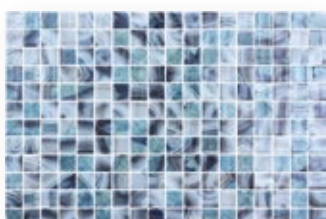

Borneo

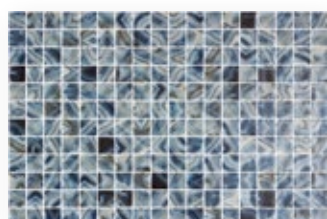

Zale

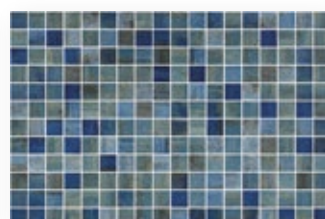

Forest Blue



Nordic Stone

Beskrivelse Glassmosaikk med uttrykk av marmor
Overflate Gloss
Formater Mosaikk 25 x 25 mm på nett. Tykkelse 4,9 mm.

Glassmosaikk med årer som fremkaller elegansen til marmor og gjensker realistiske steinteksturer, og tar oss tilbake til deres naturlige opprinnelse. Uendelige kombinasjoner av muligheter for å skape dekorative flater.

ecostones

Calacatta



Calacatta Gold



Calacatta



Statuario

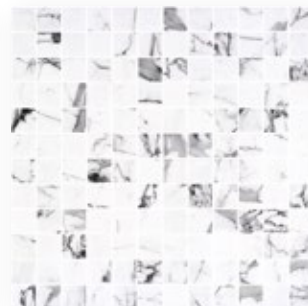

Fosco

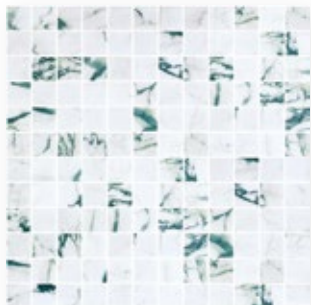

Ivy



Habana



Neon

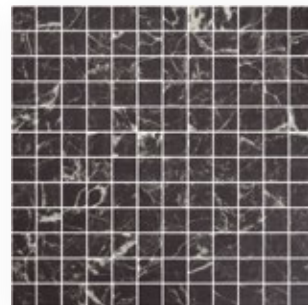

Nero Marquina

Beskrivelse Glassmosaikk med kontraster
Overflate Glossy
Formater Mosaikk 25 x 25 mm på nett. Tykkelse 4,9 mm.



Fra vannaktig blåtoner til elegante blandinger av nyanser av svart til varme toner, denne serien gir en raffinert atmosfære til svømmebassenger.

color blends

Hanalei

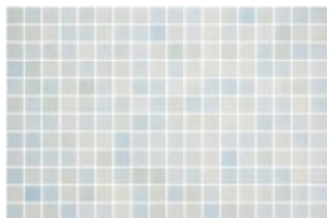

Aqua

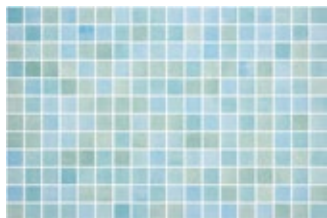

Eubea

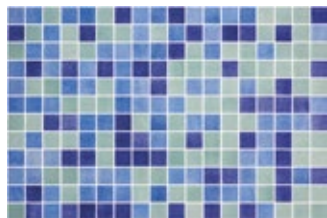

Eubea

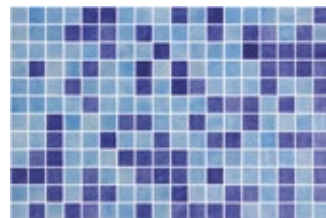

Piscis



Majestic Grey

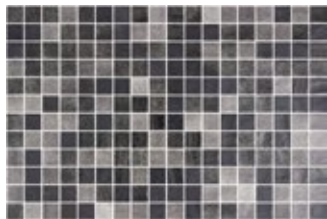

Black Scandinavian

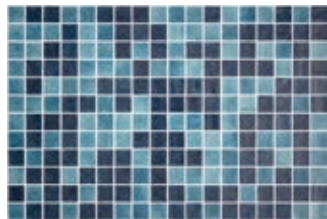

Hanalei

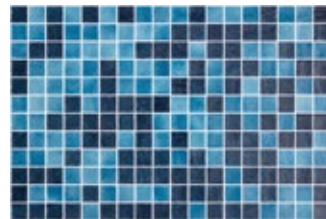

Boracay

Beskrivelse Glassmosaikk med gradert fargespill/kontrast
Overflate Glossy
Formater Mosaikk 25 x 25 mm på nett. Tykkelse 4,9 mm



Forbedre ethvert svømmebasseng med disse fantastiske Sea Shading Blends-mosaikkene.

sea shading blends



Altea

Aquamarine

Gregal

Brume

Beskrivelse Ensfarget glassmosaikk
Overflate Glossy
Formater Mosaikk 25 x 25 mm på nett. Tykkelse 4,9 mm.

En monokromatisk serie som gir kreativiteten fritt spillerom. Mosaikk med rene farger og en perfekt blank finish gjør dette til en essensiell klassiker i mosaikkens verden.

lisa



Lisa 25200

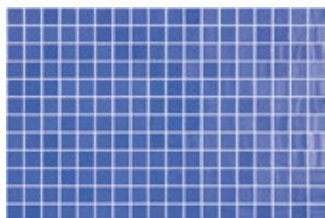

Lisa 25201

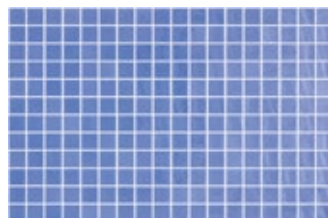

Lisa 25202



Lisa 25113

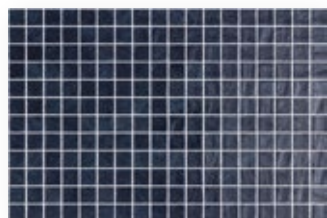

Lisa 25100

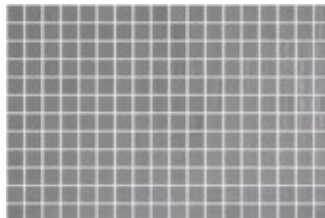

Lisa 25101

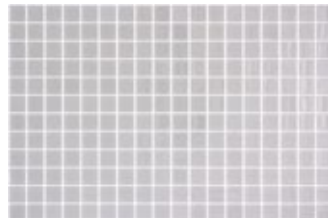

Lisa 25105



Lisa 25103



Sett en ekstra spiss på bassenget ved å legge inn maritime og lekne mønster.
Happy Pools dekorasjoner leveres med en Nieve Azul Celeste 25251 bakgrunn.
Hvis du ønsker en annen bakgrunn, må dette oppgis ved bestilling.

happy pools

Beskrivelse Farget glassmosaikk med moderat fargevariasjon

Overflate Glossy og Antislip R11C

Formater Mosaikk 25 x 25 mm på nett. Tykkelse 4,9 mm.

tilgjengelige mønster

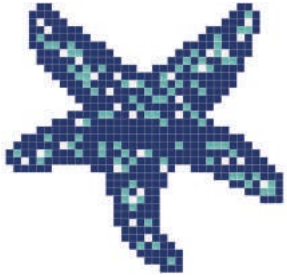

2002571 Sjøstjerne
841
1000 x 1000 mm



2002561 Anker
466
660 x 1000 mm



2002562 Sjøhest
300
330 x 1000 mm



2002563 Delfin
915
3330 x 1330 mm

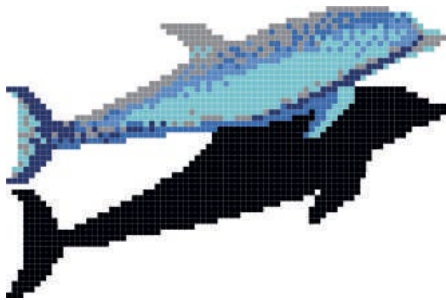

2002550 Delfin 002
907
2000 x 1330 mm



2002567 Delfiner 3
918
3000 x 1660 mm

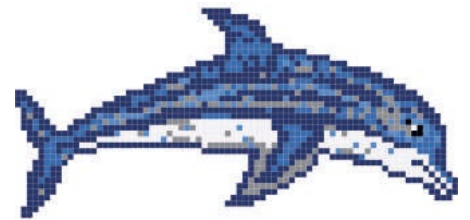

2002564 Delfin baby
907
2000 x 1000 mm



2002520 Sverdfisk
633
1500 x 2330 mm



2002566 Delfiner 2
921
3000 x 3000 mm

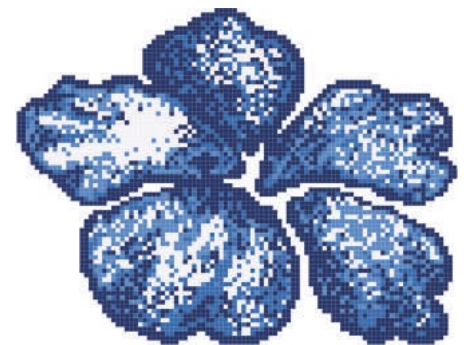

2002564 Blomst
642
2660 x 2000 mm

Vi er totalleverandør
til basseng. I tillegg til fliser,
lim og fug leverer vi også
et bredt sortiment av:

Rister til overløpsrenner

Stiger

Banedelere og bajonetter

Startblokker

Benker

Garderober



tilbehørsartikler

**bjørkebadet,
bjørkelangen**





giskehallen,
sandnes



Fotograf: Hugo Lütcherath



Fotograf: Hugo Lütcherath

Modena sine dusj- og garderobeløsninger er nøye utvalgte kolleksjoner med fokus på både funksjonalitet og stil. Våre produkter legger til rette for en komfortabel og praktisk opplevelse for brukerne.

dusj og garderober



Kvalitet, funksjonalitet og holdbarhet var og er de viktige fordelene med Pro Granitt serien. Det brede utvalget bygger på ColorONE og ColorTWO sortimentet, støtter det kreative og variable potensialet av de enkelte prosjektene, inkludert en rekke spesielle forsyninger. Alle overflater oppfyller de høye tekniske kravene av internasjonale standarder.

pro granitt

Beskrivelse Uglaserte fliser

Overflate Matt

Formater 60x60 cm, 30x60 cm, 30x30 cm, 20x20 cm

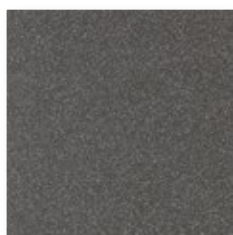

Rio Negro

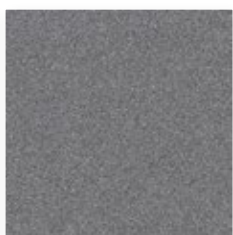

Antracit



Nordic

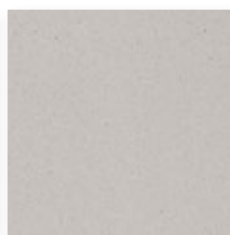

Sierra

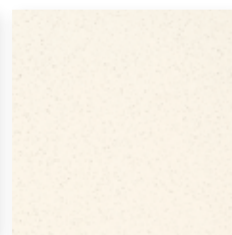

Alaska

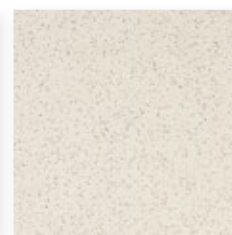

Sahara



Tunis



Cuba

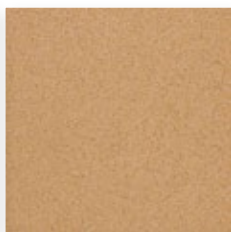

Gobi*

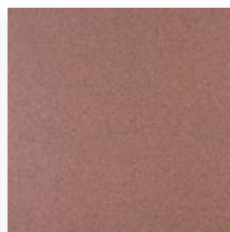

Jura*



Oaza*

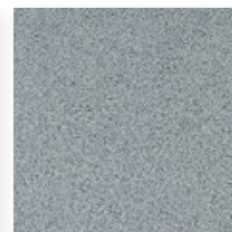

Biskay*

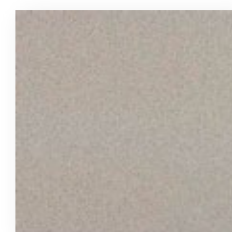

ABS



Relieff

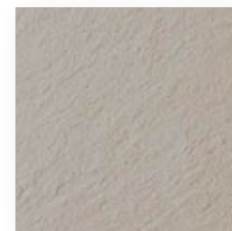

Struktur

*Kun 30x30 cm

hotell og spa

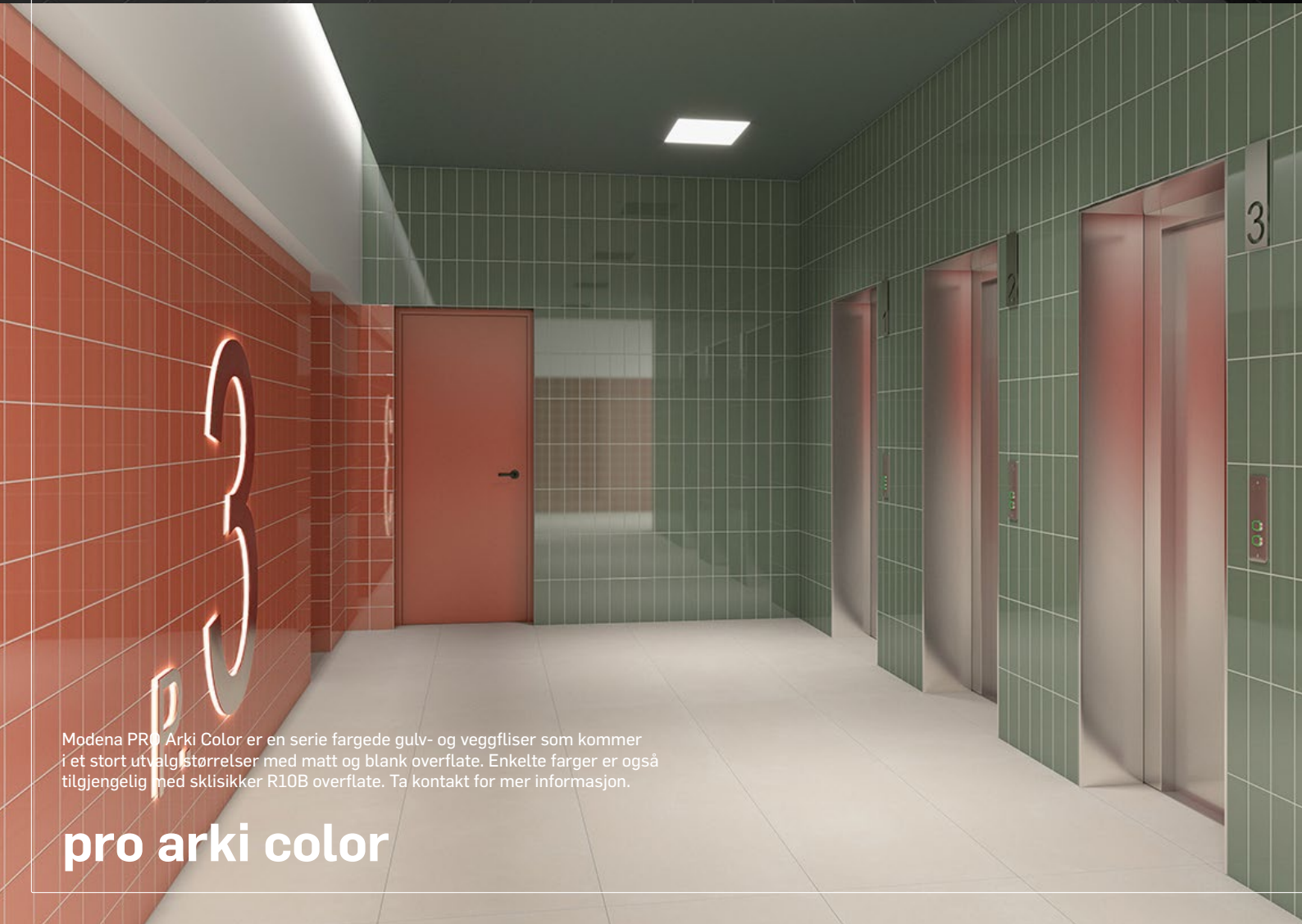

Modena PRO Arki Color er en serie fargede gulv- og veggfliser som kommer i et stort utvalg størrelser med matt og blank overflate. Enkelte farger er også tilgjengelig med sklisikker R10B overflate. Ta kontakt for mer informasjon.

pro arki color

Beskrivelse Glaserte fliser
Overflate Blank og Matt
Formater 10x30 cm, 20 x20 cm, 30x30 cm



White NCS 1000-N Pearl Grey NCS 1502-Y50R Silver Grey NCS 2500-N Steel Grey NCS 3500-N Lead Grey NCS 4500-N Deep Grey NCS 5502-R Anthracite Grey NCS 8502-B Black NCS 900-N



Petrol Blue NCS 5030-R90B Atlas Blue NCS 3030-R90B Artic Blue NCS 5020-B10G Caribbean Blue NCS 2030-B Sky Blue NCS 2020-B Crystal Blue NCS 1510-B50G Ice Blue NCS 2005-B20G Grey Blue NCS 4005-B80G



Sea Green NCS 3020-B90G Water Green NCS 1510-G Victorian Green NCS 6020-B90 Safari Green NCS 6010-G50 Argil Green NCS 4005-Y20R Savannah Grey NCS 5502-Y Mocha NCS 8010-Y90R Taupe NCS 5005-Y50R



Gemstone Beige NCS 3005-Y20R Greige NCS 4010-Y50R Natural Pearl NCS 3005-Y20R Jasmine NCS 1505-Y30R Pearl NCS 1005-Y10R Mustard NCS 2030-Y10R Yellow NCS 1070-G90Y Tangerine NCS 1060-Y50R



Amber NCS 2040-Y20R Kalahari Beige NCS 1515-Y20R Bahamas Beige NCS 3010-Y30R Burgundy NCS 4040-R Terracotta NCS 5030-Y80R Carmine NCS 2570-Y90R Purple NCS 3040-R40B Orchid NCS 2030-R10B



bjørkebadet,
bjørkelangen



hardangerbadet,
øystese



hardangerbadet,
øystese



Våre fliser til hotell og spa gir deg muligheten til å skape elegante og funksjonelle miljøer. Med fokus på høy kvalitet og og estetisk appell, er våre fliser designet for å imponere og vare.

hotell og spa

Beskrivelse Matte fliser
Overflate Naturale, levigato og strutturato
Formater 120x60 cm, 120x20 cm, 60x60 cm, 60x30 cm. Mosaikk 30x30 cm.



Fem nøytrale farger og tre utførelser gir flisen en designdrevet eleganse. Ulike alternativer for innendørs og utendørs, i ulike former og størrelser. Styrke, balanse, prakt. Den naturlige steinen kommer frem og blander seg med det tekniske porselenets overlegenhet, som gir liv til et stilig og komplett utvalg.

pietre quarzite



Ghiaccio naturale

Cenere naturale

Antracite naturale

Sabbia naturale

Argento naturale

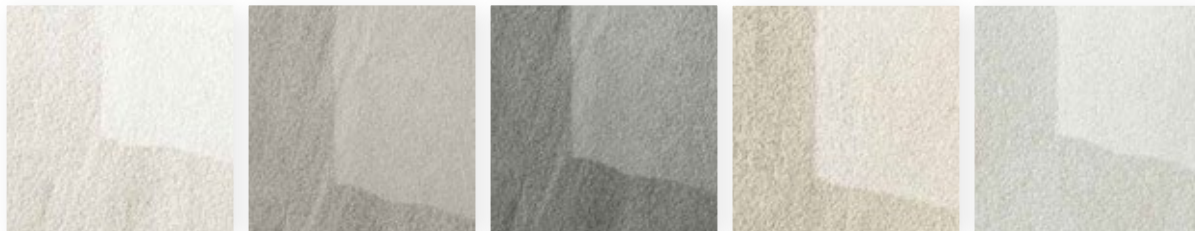

Ghiaccio levigato

Cenere levigato

Antracite levigato

Sabbia levigato

Argento levigato



Ghiaccio strutturato

Cenere strutturato

Antracite strutturato

Sabbia strutturato

Argento strutturato

Beskrivelse Matte fliser
Overflate Smooth, naturale og framed
Formater 120x60 cm, 60x60 cm, 60x30 cm. Mosaikk 30x30 cm. Stavmosaikk 30x30 cm.

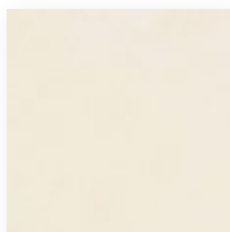

White purity

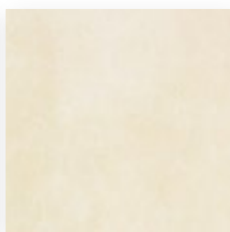

Sand heart

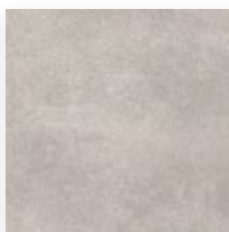

Pearl mind

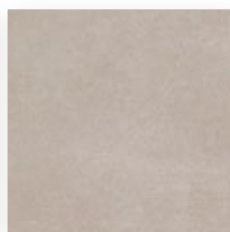

Turtle blaze

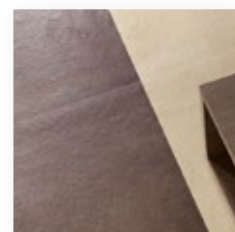

Smooth



Grey calm

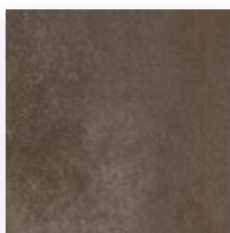

Coffee truth



Dark depth

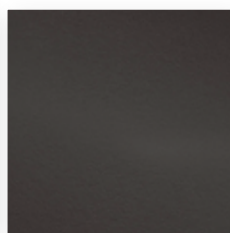

Black intensity

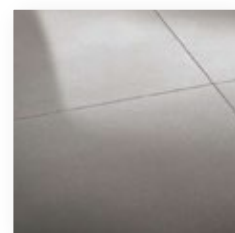

Naturale

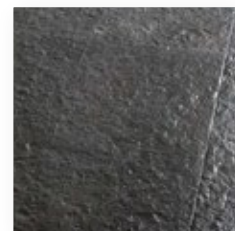

Framed

Tilgjengelig i 8 fargenyanser og 3 overflater (innrammet, struktur med anti-skli spesielt egnet for utendørs, naturlig for innendørs og utendørs, glatt, finslipt, spesielt for innendørs). Et gulv- eller veggdekkemateriale, for legging uten fuger eller minimal fuger (helst med matchende fugemasse), ideelt for ventilerte gardinvegger og forhøyede gulv.

roads

hotell og spa

Beskrivelse Matte fliser
Overflate Naturale, levigato og strutturato
Formater 120x120 cm, 120x60 cm, 120x20 cm, 60x60 cm, 60x30 cm, 20x20 cm.



Det ypperste av keramisk terrazzo, som med ny teknologi blir gjennomgående fargefragmenter tilsvarende ekte terrazzo, samtidig som den har egenskaper og bruksområder som tilsvarer keramisk flis. Venice Villa har uendelig med forskjellige grafiske variasjoner i serien for å skape et mest mulig naturlig resultat.

venice villa

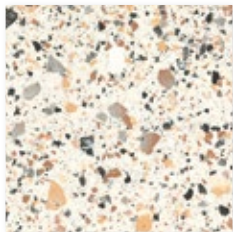

Ivory

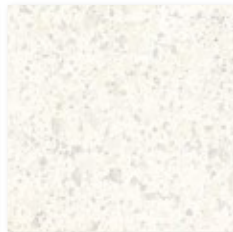

Zinc

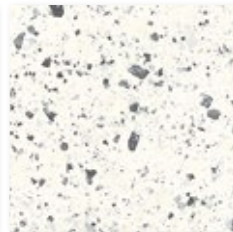

White

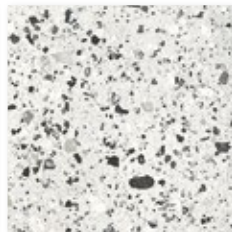

Silver

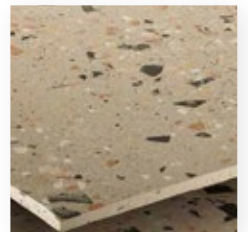

Natural

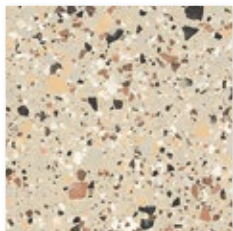

Beige

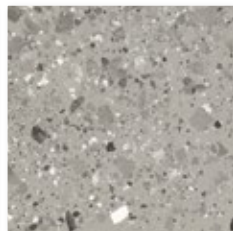

Grey

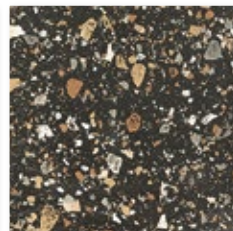

Earth

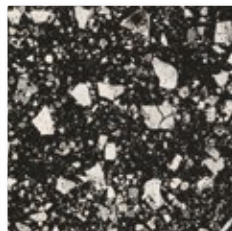

Graphite



Levigato

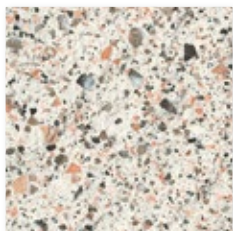

Pink

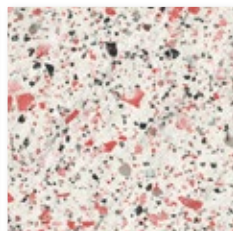

Coral

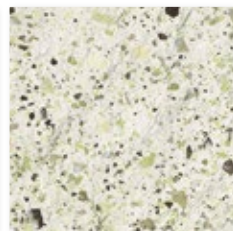

Green

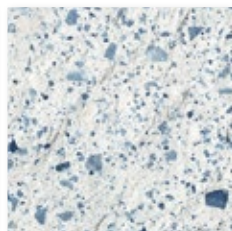

Blue



Strutturato

Beskrivelse Matte fliser
Overflate Natural, velvet og structured
Formater 120x60 cm, 60x60 cm, 60x30 cm, 30x30 cm.

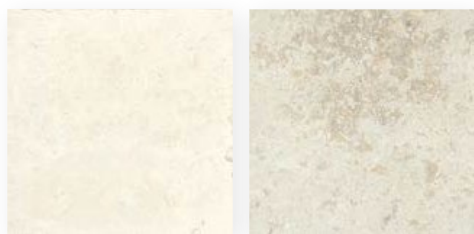
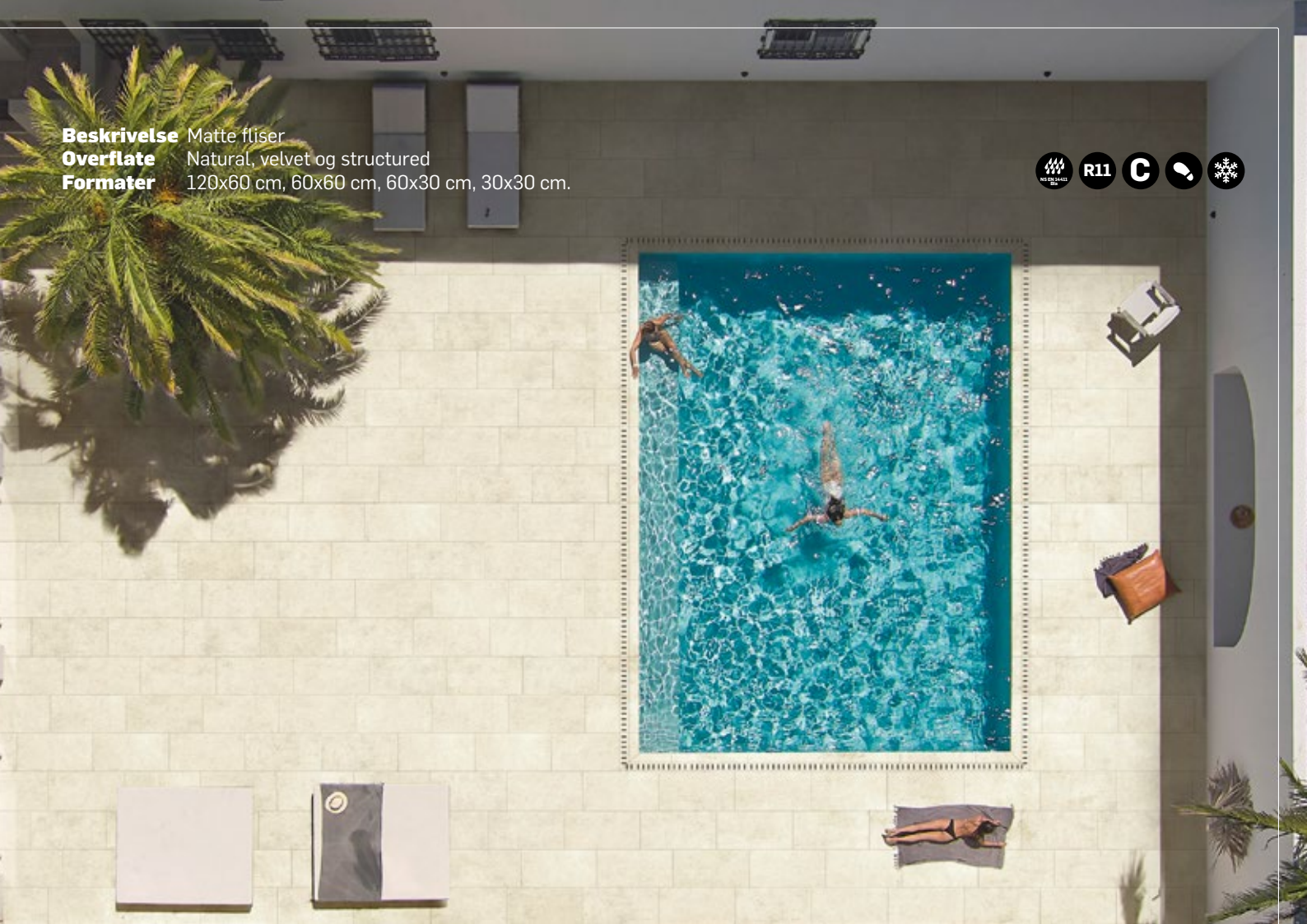

Ostuni

Cadiz



Arles

Avignone

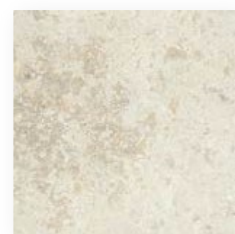

Natural

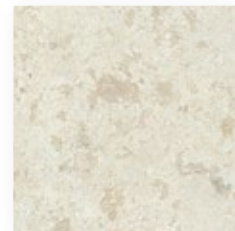

Velvet

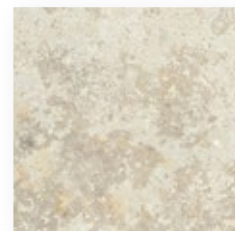

Structured

Skjønnheten fra fire typer middelhavskalksteiner gir liv i en ny syntese av natur og innovasjon. Naturlige råvarer, en bærekraftig, state-of-the-art produksjonsprosess, og en ny teknologi, brukt på struktur og overflate for første gang. En kolleksjon med en sterk visuell og taktil personlighet og en ekstremt realistisk steineffekt. StepWise teknologien tilfører anti-skli egenskaper til den myke overflaten. Skaper unike stemninger, innendørs og utendørs, i både restaureringsprosjekter og moderne rom.

uniche

hotell og spa

Beskrivelse Matte fliser

Overflate Natural og strutturato

Formater 120x120 cm, 60x120 cm, 75x150 cm, 75x75 cm, 60x120 cm, 60x60 cm, 30x60 cm



Sand



Olive



Ash



Nickel



Natural



Lead



Indigo



Carbon



Cotto



Strutturato

Svært realistisk serie som gjenskaper cotto og pigmentert betong. Serien, med sine 8 nydelige og nøytrale trendfarger, er svært anvendelig både ved bruk alene, men også i kombinasjon med andre materialer. I utvikling og produksjon av denne serien er nyeste teknologi benyttet, som igjen gir en rekke ekstreme kvaliteter i forhold til slitestyrke, sklisikring, rengjøring og vedlikehold. Cementum er et trygt og miljøvennlig alternativ.

cementum

Beskrivelse Matte fliser
Overflate Natural og strutturato
Formater 30x60 cm, 120x120 cm, 90x90 cm, 90x180 cm, 60x60 cm, 60x120 cm (20 mm), 80x80 cm (20 mm)

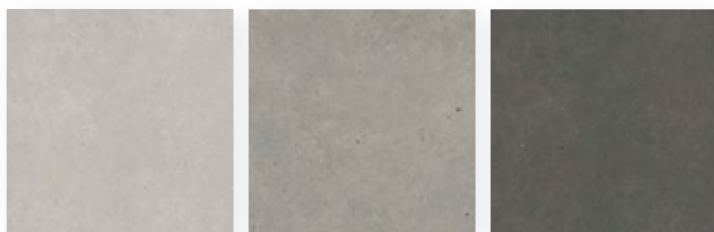

White

Grey

Anthracite



Natural

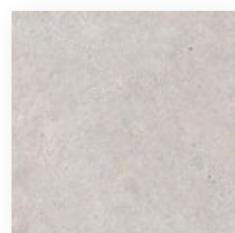

Strutturato

Diskret eleganse og en meget teknisk taktil overflate. Kombiner det med betongutseende og nøytrale toner for et minimalistisk design, eller et sammen med tre for miljøer preget av sterke kontraster. Kolleksjonen er produsert ved hjelp av den nye StepWise-teknologien, som gir antiskliegenskaper samtidig som den beholder en myk følelse, sammen med utmerkede tekniske ytelser.

mystone moon

hotell og spa



private basseng





Bilde: Minera Skifer



Bilde: Minera Skifer



Bilde: Minera Skifer

Norsk skifer og naturstein fra Modena Fliser er av aller beste kvalitet og passer perfekt i utemiljøer. Den er robust og står seg mot regn, saltvann, snø, varme, kulde, sol og forurensning. Med naturoverflate har skifer en stor grad av sklisikkerhet, noe som gjør den velegnet til bruk rundt bassenget.

naturstein



Bilde: Minera Skifer



Bilde: Alta Skifer



Bilde: Alta Skifer



Bilde: Alta Skifer



Bilde: Alta Skifer

klassifisering av sklisikkerhet

Vann på gulv i barfotområder i badeanlegg vil nedsette friksjonen og øke sklifaren. Fliser til badeanlegg er derfor inndelt i tre forskjellige sklisikkerhetsgrupper, A, B og C, hvor C har høyest sklisikkerhet. Tabell 1.2 viser aktuelle bruksområder for hver gruppe. Tabellen er veiledende og angir ikke normerte krav. R-merkede flistyper kan også benyttes i barfotområder

risikogruppe	gjennomsnittlig helningsvinkel
R9	6° - 10°
R10	10° - 19°
R11	19° - 27°
R12	27° - 35°
R13	over 35°

valg av sklisikkerhet

Hensyn til sklisikkerhet i badeanlegg er absolutt, og må alltid ivaretas, men dette kan samtidig medføre flater som er vanskelige å rengjøre. Velg derfor ikke høyere sklisikkerhetsklasse enn nødvendig. Tabellen under viser sklisikkerhetsgruppering og anvendelsesområder i hht. klassifisering etter tyske retningslinjer (DIN 51097).

sklisikringsgruppe	gjennomsnittlig helningsvinkel
A (sklivinkel 12°-18°)	<p>Barfotområder (i hovedsak tørre)</p> <p>Tørre deler av garderobeanlegg (i område nær dusjene kan det være aktuelt å bruke klasse B)</p> <p>Bassengbunn i bassengområde for ikke-svømmende med vanndybde over 0,8 meter i hele bassenget</p>
B (sklivinkel 18°-24°)	<p>Barfotområder (fliser som ikke kan grupperes under A)</p> <p>Dusjer</p> <p>"Våte" arealer i omkleddingsrom (nær dusjonen)</p> <p>Områder for desinfeksjonsspraying</p> <p>Gulv i bassenghall rundt basseng</p> <p>Bassengbunn:</p> <ul style="list-style-type: none"> • i bassengområder for ikke-svømmende, hvis vannnyben i bassenget er mindre enn 0,8 meter • i bassengområder med bølgeanlegg for ikke-svømmende • i bassenger med heve-/senkebunn <p>Grunn barnebasseng</p> <p>Leidere som fører ned i vann</p> <p>Trapper med bredde på maks 1 meter og med gelender som fører ned i vann på begge sider</p> <p>Leidere og trapper utenfor bassengområdet</p>
C (sklivinkel over 24°)	<p>Trapper og ramper som fører ned i vann, hvis de ikke kan klassifiseres under B</p> <p>Gjennomgangsbasseng</p> <p>Skrå bassengkanter</p>

teknisk info

Hos Modena Fliser har vi gått til det skritt å kvalitetsmerke våre fliser. Dette har vi gjort for å gjøre det enklere for våre kunder å plukke ut egnede fliser etter behov. Modena Fliser er en faghandel hvor en skal få den hjelp og de råd man trenger for å ha mulighet til å få et tilfredsstillende resultat. Det skal være trygt å handle hos Modena Fliser.

kvalitetsmerking av fliser



VEGGFLIS: Keramisk flis kun anbefalt til bruk på vegg. Høyere vannoppsug enn gulvfliser. Bør ligge innenfor 16% vannoppsug.



GULVFLIS: Keramisk flis velegnet for gulv. Kvalitet og overflate bør tilpasses bruksområde. Vannoppsug bør ligge på maks 3%.



GULV/VEGG: Keramisk flis, kvalitetsmessig en gulvflis, men også velegnet for vegg.



SKLISIKKERHET BARFOT: A er minst skliskikker og brukes i garderobes og andre tørre rom.



SKLISIKKERHET BARFOT: B er middels skliskikker og brukes i dusjer og gulv rundt basseng.



SKLISIKKERHET BARFOT: C er mest skliskikker og brukes i trapper som føres ned til vann og skrå bassengkanter.



SKLISIKKERHET SKO: Kan benyttes i de fleste rom i private boliger. Utendørs anbefales bedre skliskikker enn R9.



SKLISIKKERHET SKO: Velegnet til de fleste gulv i private boliger, men vanskeligere å holde rene enn R9. Kan vurderes til gang/ inngangspartier og utendørs.



SKLISIKKERHET SKO: R11 er egnet til flere gulv i private boliger. Vurder vaskbarheten først. Perfekt til inngangspartiet/ gangen, utendørs og garasjen.



SKLISIKKERHET SKO: Innendørs kun i inngangspartier. Meget skliskikker, perfekt utendørs, renholdet krever mer.



SKLISIKKERHET SKO: Unngå bruk i private boliger. Kan brukes utendørs, kan være vanskelig å holde rent.



UGL: Uglaseret flis m/gj.farget gods. Som regel meget slitesterk (høypolert overflate). De fleste UGL-fliser har NS EN 14411 Bla kvalitet (Porcellanato).



SLITASJEMOTSTAND: Gjelder kun glaserede gulvfliser. Til gulv med lett slitasje. Kun til barfotområder.



SLITASJEMOTSTAND: Gjelder kun glaserede gulvfliser. Til gulv med middels slitasje (baderoms-gulv, soverom etc.)



SLITASJEMOTSTAND: Gjelder kun glaserede gulvfliser. Til gulv med stor slitasje (inngangspartier, kjøkken, stue, kontor, offentlig etc.)



SLITASJEMOTSTAND: Gjelder kun glaserede gulvfliser. Til gulv med meget stor slitasje (restauranter, resepsjoner, offentlig etc.)



FROSTSIKKER: Maks vannoppsug på 0,5%. Går ofte under benevnelsen Porcellanato. Ekstremt viktig med fall, limdekning og skliskikkerhet.



MOH: Forteller oss om ripefastheten på produktet, dvs hvor mye flisen tåler før det kommer riper. MOH blir kun målt på glaserede fliser. MOH 7 er egnet for inngangsparti.



NS EN 14411 Bla: Tørrpresset keramisk flis. Vannoppsug < 0,5%. Tillatte dimensjonsavvik lengde/ bredde +/-0,6%, opptil +/-2mm.



NS EN 14411 Blb: Tørrpresset keramisk flis. Vannoppsug < 3%. Tillatte dimensjonsavvik lengde/ bredde +/-0,6%, opptil +/-2mm.



NS EN 14411 Blla: Tørrpresset keramisk flis. Vannoppsug 3% < E < 6%.



NS EN 14411 Blll: Tørrpresset keramisk flis. Vannoppsug < 10%. Tillatte dimensjonsavvik lengde/ bredde +/-0,5%, opptil +/-2mm.



NS EN 14411 Alla: Våtpresset keramisk flis. Ofte kalt klinker. Vann-oppsug 3% < E < 6%. Tillatte dimensjonsavvik +/-2%.



RETTSKÅRET: Kan legges med minimale fuger. Hver flis er kalibrerte i størrelsen. Gir et eksklusivt preg.



V1: Jevne farger med minimale forskjeller mellom fliser fra samme produksjonsparti.



V2: Merkbart variasjon av struktur og mønster i fliser fra samme produksjonsparti. Anbefales å se på varen før den velges.



V3: Tydelig variasjon i struktur, mønster og farger fra samme produksjonsparti. Anbefales å se på varen før den velges.



V4: Tilfeldige forskjeller mellom flisene. En flis kan ha en helt annen struktur og farge enn andre. Anbefales å se på varen før den velges.



≥4MM: Anbefalt minimum fugebredde. For små fuger kan gjøre flisarbeidet vanskelig og resultatet ikke tilfredsstillende.



DIGITAL: Digital produksjon gir et mer ekte og naturtro design, samtidig som man kan oppnå et resultat der hver flis har sitt unike mønster.



SPELALVERKTØY: Noen fliser kan virke harde og vanskelige å tilpasse uten spesialverktøy. Sigma Max flisekutter, flissag og diamanthullbør bør brukes.



ECO: Keramiske fliser produsert på en miljøvennlig måte. Resirkulering og minimal forurensing er viktige stikkord.



NS EN 14411 A1b: Våtpresset keramisk flis. Ofte kalt klinker. Vann-oppsug > 3%. Tillatte dimensjonsavvik +/-2%.



≥6MM: Anbefalt minimum fugebredde. For små fuger kan gjøre flisarbeidet vanskelig og resultatet ikke tilfredsstillende.



≥7MM: Anbefalt minimum fugebredde. For små fuger kan gjøre flisarbeidet vanskelig og resultatet ikke tilfredsstillende.

*Vår kvalitetsmerking er basert på de europeiske kvalitetsstandardene.

Våre fliser produseres med grafiske variasjoner for å skape mest mulig naturtro uttrykk. Selv med mange ulike grafiske overflater, vil man i praksis kunne finne samme mønster i samme eske. Det er derfor viktig å plukke fliser fra forskjellige esker ved montering. I tillegg må man også visuelt overvåke dette ved montering. Mangler eller avvik må meldes Modena umiddelbart. Montert produkt er å anse som akseptert og godkjent av mottaker/kunde. Vi viser ellers til våre salgs- og leveringsbetingelser på modena.no.

modena

Fliser – inspirert av naturen



Finn din lokale proffselger eller spesialist
på www.modenaprojekt.no

Det tas forbehold om at produkten vist i Modena Bassengprogram,
kan bli endret til lignende eller tilsvarende produkt.
Ta kontakt med din proffavdeling for mer info om beholdning og leveringstid.
Se våre Salgs- og Leveringsbetingelser på modenaprojekt.no

modenaprojekt.no